

40185
8245

[All rights reserved.]

HANDBOOK

FOR THE

16-PR. R.M.L. GUN OF 12 CWT.

(MOVABLE ARMAMENT AND BATTERIES OF
POSITION, VOLUNTEER ARTILLERY.)



1900.



LONDON:

PRINTED FOR HER MAJESTY'S STATIONERY OFFICE,
BY HARRISON AND SONS, ST. MARTIN'S LANE,
PRINTERS IN ORDINARY TO HER MAJESTY.

And to be purchased, either directly or through any Bookseller, from
KYRE & SPOTTISWOODE, EAST HARDING STREET, FLEET STREET, E.C.; or
JOHN MENZIES & Co., 12, HANOVER STREET, EDINBURGH, and
90, WEST NILE STREET, GLASGOW; or
HODGES, FIGGIS, & Co., Limited, 104, GRAFTON STREET, DUBLIN.

1900.

Price One Shilling.

1149

CONTENTS.

	PAGE
Gun	3
Sights	3
Care and Preservation of Gun and Fittings	4
Rifle, Aiming	5
Carrriage and Limber	6
Ammunition Wagon	7-8
Care and Preservation of Carrriages, &c.	8-9
Charges	9
Projectiles	9-10
Distinguishing Marks on Projectiles	10
Fuzes	11-14
Primer, Fuze	14
Tubes	15
Range Table	16
Drill	18
Instructions for Using the Clinometer	35
Range Finder	36

DIAGRAMS OF PACKING.

Carrriage and Limber (Movable Armament)	38
Ammunition Wagon and Limber (Movable Armament)	39
Carrriage and Limber (Volunteer Batteries of Position)	40
Ammunition Wagon and Limber (Volunteer Batteries of Position)	41

PLATES.

Gun	I
Carrriage	II
Limber	III
Wagon	IV
Projectiles	V
Fuzes	VI to IX
Tubes	X

This handbook is corrected up to May 1900. Any alterations which may be suggested should be forwarded to Chief Inspector, Woolwich Arsenal.

16-PR. R.M.L. GUN OF 12 CWT., MARK I.

DESCRIPTION.

GUN.

(Plate I.)

	Material	Steel and wrought iron.	
	Length	{	nominal	74.45 inches.	
			total	78 inches.	
	Weight, nominal	12 cwt.	
	Preponderance	7.5 lb.	
	Bore	{	calibre	3.6 inches.	
			length	68.4 " = 19 calibres.	
			capacity	706 cubic inches.	
			system	French modified.	
	Rifling	{	twist	Uniform, 1 in 30 calibres.	
			length	58.4 inches	
			grooves	number	3.
				depth	0.11 inch.
width	0.8 "				
	Vent, hardened copper	0.6 inch from end of bore.	

The gun consists of a steel "A" tube, over which is shrunk a wrought iron jacket with trunnions, the cascable being in one piece with the "A" tube.

A plane for clinometer is prepared on the jacket immediately in front of the vent.

SIGHTS.

The gun is provided with two tangent sights and two fore-sights. The tangent sights are set at an angle of 1° 50' to the left for correction of drift. The sight bars, which are of steel, rectangular in section, are graduated on the muzzle face to 12 degrees, and on the right and rear faces with a fuze and yard scale respectively, the latter extending to 4,000 yards, with a muzzle velocity of 1,355 f.s. The cross-head, which is fitted with a deflection leaf, gives 30 minutes deflection right and left, and was formerly furnished with a slow motion nut for fine adjustment in elevation, but this is now fixed by having a rivet passed through the upper portion of the nut and the sight bar.

Sights so altered are designated Mark II. Sights of future manufacture will be made with the bar and crosshead solid, and will be known as Mark III.

The tangent sights are clamped by means of copper set screws secured to the gun, and their removal is prevented by a pin screwed into the side of the breech.

The fore-sight consists of a steel pillar screwed into the gun near the trunnion, having a steel leaf and fixing screw.

A wrench is provided for removing the sight when necessary.

CARE AND PRESERVATION OF GUN AND FITTINGS.

(Based on Instructions contained in "Regulations for Magazines and the Preservation of Artillery Matériel.")

A "Memorandum of Examination" is issued with each gun. It contains a drawing showing the principal dimensions, with a short description of the construction and rifling, as well as the particulars of any slight original defects or tool marks which may have existed at the date of issue. In it are recorded in detail the number of rounds fired, and the date and result of any examination.

This memorandum will remain in charge of the officer who has possession of the ordnance, and a certificate to the effect that it is in possession and complete up to date will be included in the annual return of rifled ordnance, Army Form G 872.

At the conclusion of each day's firing an entry will be made in the memorandum by the officer in charge, giving a detail of the rounds fired, so that an accurate record of the firing may always be kept up.

A statement of the results of examination will be added to the memorandum by the inspecting officer, or other examiner, who performs the duty, and when the gun is returned into or issued from store the memorandum will cover the vouchers.

If at any time the memorandum be lost or damaged, a duplicate can be obtained from the Chief Inspector, Woolwich, by whom also inside sheets for continuation of the record of the number of rounds fired will be supplied on demand.

The gun will, as far as possible, be examined after firing 150 rounds, and practice from such ordnance should cease until such examination has been carried out. In cases, however, where such examination would happen within a series of rounds allowed for practice, and thus cause inconvenience, the gun will be examined before practice commences, irrespective of the number being completed.

In computing the number of rounds for examination purposes, four rounds of blank charges may be regarded as equal to one round with projectile, but in recording the number on the memorandum of examination, "blank" rounds should be shown as such. Ordnance used for saluting purposes or for time guns should, however, be examined at least once a year, or oftener if necessary.

The exterior of the gun will be painted biennially, and the bore will be lacquered at the conclusion of each year's practice, when, in addition, the vent will be plugged, and all fittings liable to damage by exposure will be removed.

During practice the bore will be kept slightly oiled to prevent rusting; at the close of each day's practice the gun will accordingly be washed out and placed under metal, and as soon as dry, the bore will be oiled and the muzzle closed with a tampon.

The clinometer plane is not to be painted, and it is on no account to be cleaned by filing, or by the use of brickdust. It must be cleaned by a soft rag, and afterwards slightly oiled.

The sights must be kept clean, free from grit, and oiled, and the sliding leaves of the tangent sights must have free play; on no account are the sights to be burnished or cleaned in such a manner as to remove the bronzing or bluing.

Preserving and fixing screws should be occasionally removed and slightly oiled, to prevent them from setting fast.

RIFLES, AIMING, M.-II. CHAMBER, EWART.

This apparatus is for use with the gun in imparting instruction in laying, and consists of the following parts:—

Rifles, aiming, M.-II. chamber, Ewart:—

Bands	Bronze.
Front	With securing bolt, nut, and washer.
Rear	With securing bolt, nut, and washer, buffer, and key.
Barrel, rifle	M.-II. rifle barrel, with breech action and metal boss.
Cord, firing	White line, tarred, 2 yards long (with two hooks).
Lever, vent	Steel.
Link, trigger	Bronze, with fixing screws.
Tube, 0.23-inch "T"	Including breech-piece, bushes (movable and fixed), set nut, and leather washer.
Lanyard, friction tube, siege, No. 1.	With toggle, 5 feet 5 inches.
Tube, friction, drill	Dummy iron, with spring clip.
Tube, 0.23-inch—	
Brush, cleaning.	
Key, M.-II.	
Rod, cleaning.	

METHOD OF FITTING, ADJUSTING, AND USING THE APPARATUS.

The aiming rifle is fitted to the left side of the gun in the following manner:—

The two bands are placed over the chase of the gun, the distance between the inner faces of the bands being 27 inches. The bands are secured round the gun by fixing bolts. The muzzle of the rifle is passed through the hole in the arm projecting from the front band, and the breech is placed in the socket on the rear band and fastened with a key. A buffer spring, to lessen the strain on recoil, fits into the socket in rear of the rifle. A hole is made at the rear end of the socket to facilitate the extraction of the buffer spring.

To adjust the rifle on the gun, the latter is laid horizontally; the 0.23-inch tube, "T," is then inserted in the bore of the rifle, sufficient length being allowed to project from the bore to admit of the application of a spirit level to the 0.23-inch tube, by which means the rifle is

levelled, so that the axis of rifle and gun are in parallel horizontal planes. The bands are then firmly screwed up, care being taken to see that they do not shift during the operation, in the event of which they must be slackened and re-adjusted.

Elevation is obtained by means of the gun sights, and any error in line is corrected by use of the deflection scale.

The rifle is fired by means of the firing cord, one end is hooked to the loop of the "link, trigger," and the other end to an arm of the "lever, vent"; the Service "lanyard, friction tube, siege, No. 1," is then hooked to the other arm of the "lever, vent," the latter being held in position by the service dummy tube.

CARRIAGE AND LIMBER, MARK I.

The carriage is formed of two bracket sides, connected by transoms, bolts, and a trail plate; an axletree bed with axletree and field wheels.

Each bracket side is constructed of plate iron rivetted to the outer sides of an angle iron frame.

The trail plate is of the same form as in the wood field gun carriage; its eye is steeled to prevent wear.

The axletree bed is of wrought iron, constituting with the axle a beam of box-girder section, which is connected to the brackets by stays. A deflector, which is fitted with a pendulum to indicate on a degree scale the difference in the height of the wheels, is suspended by loops from the axletree bed.

The wheels are of the 2nd class with metal nave.

The elevating screw is attached to the cascable of the gun by a bolt, and is worked by a metal nut, through which it passes. Bevel teeth are cut upon the lower part of the nut, which gears with a bevel wheel upon a horizontal spindle. The vent and bevel wheel are contained in a wrought iron box, having a trunnion upon each side, supported in bearings bolted to the brackets. The lid of the box is secured to the bottom by four screws; it has a lubricating hole, filled by a metal screw, and a drip hole in the bottom. The spindle of the bevel wheel passes through a metal bearing in the right trunnion of the box, worked by a hand wheel on the right side of the carriage.

The axletree boxes are fitted with guard-irons and sliding foot-rests, in order that they may serve as seats. Each carries two rounds of ammunition and small stores.

A leather guard is fitted to the lid of the near box to protect the gunner's overalls from contact with the sponge head.

The limber is formed on the same plan as the wood limber, but has the futchels and splinter bar of iron.

To support the ammunition boxes four knees of T-iron are secured to the back of the bed.

The limber hook is steeled to prevent wear, and has a steel key.

The axletree is the "light field" axle (2nd class), and the wheels are the same as those for the gun carriage.

The shafts are "near" and "off," the latter known as the "Brandling" pattern; they are fitted for farmers' draught; and the limber is fitted for single, double, treble, and bullock draught.

The limber boxes are "near," "off," and "centre"; the "near" and "off" carry each 12 projectiles in trays, and as many cartridges in a canvas cartouche.

CARRIAGE AND LIMBER, MARK II.

(Plates II and III.)

The carriage differs from Mark I carriage in having the plate of each bracket placed on the inner instead of the outer side of the frame; and in the trail piece, which lies between the brackets instead of overlapping them.

The wheels and elevating screw are the same as in Mark I carriage; the axletree boxes are similar but not interchangeable with those of Mark I.

The limber differs from Mark I in having an iron (box-girder) axletree bed instead of wood, and in the form of the limber hook, which is made to stand out from the bed, and so obviates the necessity of a block between them.

The wheels and boxes are the same as in Mark I limber.

		Mark I.		Mark II	
		ft.	in.	ft.	in.
Height, centre of Gun	3	7 $\frac{1}{2}$	3	7 $\frac{1}{4}$
Length of	carriage { with wheels	..	10 3	10	3
	{ without wheels	..	9 0	8	10
axletree	6 3 $\frac{1}{2}$	6	3 $\frac{1}{2}$
	carriage and { without gun	..	21 0 $\frac{1}{2}$	21	2
limber	{ with gun	..	22 10	23	0
Minimum space through which carriage can					
turn	32 4	32	9
Angle of trail	22°	24°	
Angle of lock	51°	54 $\frac{1}{2}$ °	
Elevation, maximum	22 $\frac{1}{2}$ °	17 $\frac{1}{4}$ °	
Depression, maximum	12 $\frac{1}{4}$ °	15°	
Wheels	track	5 2	5 2
	diameter	5 0	5 0
Weight of	carriage, empty, with wheels, drag shoe, and elevating screw	13 1 19	13 0 0	
	limber, empty, with boxes, shafts, and wheels	11 1 9	11 0 19	
	wheels	4 2 0	4 2 0	
	elevating screw	0 0 13 $\frac{1}{2}$	0 0 13 $\frac{1}{2}$	

AMMUNITION WAGON, MARK I.

The frame of the wagon consists of a perch of girder iron, with steeled eye, and two sides of angle iron, connected together by iron plates, over which the boards are secured, namely, two footboards and three platforms.

The axletree, which is the light field axletree, 2nd class, is secured in a bed of wool bolted beneath the perch and sides.

The wheels of the wagon are the same as for the gun carriage.

The wagon is fitted with a sabicu block with arm for carrying a spare wheel, and has also fittings for carrying a drag shoe and stores.

The ammunition boxes (four) stand between the platform boards secured by nib irons and straps; two are the same as the "near" gun limber box, and two the same as the "off," excepting lid fittings. Beneath the wagon are two under boxes.

The wagon limber is identical with the gun limber.

AMMUNITION WAGON, MARK II.

(Plate IV.)

This wagon differs from Mark I in having an iron axletree bed, similar to that of the gun carriage, instead of a wooden one; in the perch being formed of channel iron in two parts, with strengthening plates instead of solid girder iron; and in the block for the spare wheel being of iron instead of wood.

The perch resembles the trail of the gun carriage in its general form, and is rivetted to the axletree bed.

The wheels, ammunition boxes, &c., are the same as in Mark I wagon.

The wagon limber is identical with the gun limber.

	Mark I.		Mark II.	
	ft.	in.	ft.	in.
Length of wagon and limber.	20	5½	20	7½
Minimum space through which wagon can turn	29	8½	29	6
Weight of wagon and limber, empty.	cwt. qrs. lb. 26 0 13		cwt. qrs. lb. 27 2 4	

INSTRUCTIONS FOR CARE AND PRESERVATION.

All bearings should be kept clean and slightly oiled, and all nuts tightly screwed up. Linch pins, washers, the end of the wheel iron of the off shaft, and axletree arms should be kept perfectly clean, care being taken in cleaning them not to rub them away too much, and so reduce them in size; they can be kept slightly oiled, but if so the old oil must be frequently rubbed off and fresh put on. Carriages kept in store should have the bright parts of the iron work coated with grease. Water should not be allowed to lodge in any of their recesses.

Defects or damages should be made good without delay, and if the paint becomes rubbed off at any part, it should be patched over as soon as possible. Opportunity should be taken of the annual painting to give the carriages of a battery a thorough overhauling and repair.

Elevating Screws.

Elevating screws should be kept clean and oiled; if they do not run up and down freely, they should be removed and examined; if the threads are indented on the edges, they must be neatly filed down. If the bevel pinions in the box have become indented or choked up with clotted oil and dirt, the box should be opened, the necessary adjustments made, and the inside of the box painted with red lead.

Cap-squares.

The inside of the cap-squares and the trunnion bearings must be kept clean and oiled.

The lugs and the crown of the cap-square are liable to be "drawn," giving too much play to the trunnions of the gun. The cap-square should be repaired as soon as possible, as the deformation otherwise will rapidly increase in firing, and the lugs will be broken.

Bolts.

All bolts should be kept tightly nutted up. Sometimes a particular nut will work loose continually; in such cases, after tightening it up, cut the thread of the bolt across close up to the nut, and caulk it under a little.

Care must be taken, in painting, that no *working* parts are painted, and intelligence must be exercised in keeping the working surfaces free from paint. Such parts must, on the other hand, *on no account be polished*, but kept clean by greasing or oiling. If they are not in constant action, a coating of oil will preserve them from rust and not collect dust.

AMMUNITION.

CHARGES.

Service { 3 lbs. 3 ozs., R.L.G.⁴, silk cloth.
 { 3 R.L.G. or R.L.G.², serge.
 Saluting, 1½ lbs., blank, L.G., silk cloth.

The silk cloth cartridges are of No. 1 class silk cloth, hooped with silk braid, and choked with silk twist.

The serge cartridges are hooped with worsted braid and choked with worsted.

Filling and examining cartridges, &c., see "Magazine Regulations" and "Regulations for Army Ordnance Services."

Drill Cartridges.

These are of raw hide.

PROJECTILES.

(Plate V.)

Nature.	Mark.	Bursting Charge.		Weight.
		Weight.	Powder.	
Shell { Common ..	III	1 lb. 2 oz.	P. and F.G.	16 lb. 1¼ oz.
{ Shrapnel ..	III	1¼ oz.	F.G.	17 lb. 14¼ oz.
Shot, case	I and II	15 lb. 3 oz.

Common Shell.

The common shell is of cast iron, with two rings of studs, the head being struck with a radius of 1½ cal. The interior of the shell is lacquered, and the fuze-hole is tapped to G.S. gauge. When filling a "bag, burster" of dowlas is used with these shell.

The bursting charge is in the proportion of 15½ ozs. P. and, 2½ ozs. F.G.

*Shrapnel Shell.**

The body of the shell is of cast iron, and has two rings of copper studs. The head is of Bessemer metal lined with wood, and contains a composite fuze socket of tin and gunmetal screwed to G.S. gauge. The walls of the shell are thickened near the base so as to form a shoulder, on which rests a wrought-iron diaphragm. The bursting charge is contained in a tin cup in the base of the shell, connected to the fuze socket by a gunmetal tube screwed into the diaphragm. The body of the shell is lined with brown paper, and filled with mixed metal bullets (72 at 18 per lb. and 56 at 84 per lb.) run in with melted resin.

Case Shot.†

The body is made of tin, in three parts, soldered together longitudinally. The base is strengthened by having a disc of sheet iron laid loose in the interior, and a ring of the same rivetted to the tin case outside. The sides are lined with three longitudinal segments of sheet iron laid in loose. The top consists of a disc of sheet iron secured to the case by turning over and soldering the ends of the latter. It is filled with 176 mixed metal balls at $16\frac{1}{2}$ per lb. packed in clay and sand.

Mark II differs from Mark I in being fitted with a wrought-iron handle on top to facilitate the removal of the shot from the limber boxes.

DISTINGUISHING MARKS.

Shrapnel shell will be painted with a red tip, 1 inch deep.

All filled shell will be marked in red as follows:—

- (a) A band $\frac{1}{2}$ inch wide round the head, $1\frac{1}{2}$ inches from the top; this will be $\frac{1}{2}$ inch below the red tip of Shrapnel shell, or the white band of steel shell.
- (b) The word "Bag," if one has been used.
- (c) The monogram of the station.
- (d) The date of filling.
- (e) A disc, 1 inch diameter, if shalloon primers have been inserted.
- (f) The letter "P," 1 inch long, if filled with P. and F.G.
- (g) The word "fuzed" if the shell is fuzed.

Projectiles which are to be used for practice only will be marked with a yellow band $\frac{1}{2}$ inch wide round the body.

Shells which have been emptied will be marked on the head with the letter "E," in red paint, and also the monogram of the station.

MAKING UP CARTRIDGES, FILLING SHELLS, &c.

See "Magazine Regulations" and "Regulations for Army Ordnance Services."

* Shrapnel shells can be utilised as case shot, for distances up to 100 yards, by loading the reverse way, and firing them without fuze or plug.

† Case shot, when placed in axletree boxes, should be packed with oakum, to prevent their being damaged in travelling.

FUZES.

Percussion { R.L., No. 7, Marks II*, III*, and IV.
 { Small, No. 8, Mark IV.
 Time, 15 seconds, M.L., No. 41, Mark II.
 Time and percussion, No. 56, Mark IV.

DESCRIPTION OF FUZES

*Percussion, R.L., No. 7.**(Plate VI.)*

The body is of gunmetal screwed to fit the G.S. gauge, and with a square hole in the head to fit the key by which the fuze is screwed into the shell. The bottom is closed by a screw plug.

The safety pin (of double twisted wire) passes through the head of the fuze, and is kept in its place by the two ends being opened out slightly, in the conical cup, as shown in Plate VI. A thin disc of brass is then fitted over the ends, and soldered to keep the fuze watertight. The head of the safety pin is fitted with a loop of tarred twine, by which it is withdrawn. The pin is not to be withdrawn until the shell is placed in the gun.

When the safety pin is withdrawn, the hole through which it passed, if left open, would probably admit of the passage of the flash from the discharge of the gun into the interior of the fuze, and so cause a premature burst. To guard against this, a small lead pellet slides freely in a recess cut in the head above the safety-pin hole. When the shell is rammed home, the pellet sets back, and so closes the safety-pin hole.

The percussion arrangement of Mark IV fuze consists of a steel needle, fixed in the centre of the top on the inside, and a lead pellet containing a detonator covered by a brass disc 0.005 inch thick in its head. The pellet is kept in position by a gunmetal guard, which rests on two feathers on the outside of the pellet. The guard is furnished with a feather on the outside which fits a groove in the body of the fuze, so that body and guard must rotate together. On the shock of discharge, the guard sets back on the pellet, shearing off the feathers, and on graze or impact, the guard and pellet fly forward together, bringing the detonator in contact with the needle, and thereby firing the fuze.

A shield of copper is placed over the top of the lead pellet to prevent the brass safety pin from indenting it, and thereby allowing the detonator to approach too close to the needle. Mark III has the brass disc over the detonator only 0.001 inch thick, and the guard had no feather. This pattern when converted to Mark IV is called Mark III*. Mark II had not the copper shield.

*Percussion, Small, No. 8.**(Plate VII.)*

The fuze (Mark IV) consists of the following parts:—

Body, detonator pellet, with two retaining bolts, spiral spring, safety pin, closing pellet, needle plug, and magazine.

The body is of gunmetal, screwed on the outside to the G.S. gauge. It is bored out from the top to receive the detonator pellet, and is closed by means of the needle plug. Two holes, closed on the outside by brass discs, are bored in the body to receive the retaining bolts of the pellet. Two fire-holes are bored in the bottom to communicate the flash from the pellet to the magazine, which consists of a pellet of pressed powder, secured in the lower end of the fuze by a brass disc spun in.

A detonator covered by a brass washer 0.03 inch thick is secured in a recess in the top of the gunmetal pellet, and two fire-holes, filled with F.G. powder, lead from it to the bottom, where they are closed with paper discs. The top of the pellet is reduced to fit inside a spiral spring, which prevents the pellet rebounding or working forward during flight.

The two retaining bolts, with brass spiral springs, pass transversely through the pellet (as shown in the drawing), the springs keeping them locked in the holes in the body until spun out by the rotation of the shell. A screw in the body projects into a groove down the side of the pellet, and prevents it from turning.

The needle plug has a steel needle fixed in the centre, and screws into the top of the body. A hole through the side of the fuze into the needle plug contains a brass pellet, with spiral spring behind it, for closing the safety pin-hole.

The safety pin, of twisted copper wire, passes through the needle plug, down the body, behind the head of one of the retaining bolts, and is bent over at the top into a groove in the needle plug.

Mark III differed from the above in having the detonator pellet held in position by a small screw plug, and in having no protecting washer over the detonator. In Mark II the spiral spring in front of the detonator pellet was stronger, and was replaced by the same spring as in Mark III, the fuze being then Mark II*. Marks II* and III will be exchanged for Mark III* or IV.

Mark III fuzes are converted to practically the same as Mark IV, and are then Mark III*.

Action of the Fuze.—The safety pin being withdrawn at the moment of loading, the whole is closed by the closing pellet. On discharge the centrifugal motion of the shell causes the retaining bolts to fly outwards, leaving the detonator pellet free to move forward, except for the spiral spring. On impact, the pellet compresses the spring in front of it, and moves forward on to the needle, which ignites the detonator, and so fires the fuze.

Time, 15 seconds, M.L., No. 41.

(Plate VIII.)

This is made of beech wood, with a composition channel bored almost the whole length of the centre of the fuze. This channel is lined with paper, and driven with 2 inches of slow-burning composition. Above this is an 0.6-inch pellet of mealed powder, having a hole bored down its centre to a depth of 0.4 inch. There are six powder channels bored parallel to the composition channel, connected at the bottom by quick-match placed in an annular groove and pressed into the bottom of each channel. The last hole is bored through and threaded with quick-match. The numbers on the paper scale are reversed, so that they read correctly when the fuze is being bored. Each side hole is marked on the index paper with a dot of yellow paint. The head of

the fuze is closed by a gunmetal plug, round the pin of which quick-match is looped and let through two fire-holes to a groove round the head. This groove is covered by a copper and tape band which must be removed before firing.

The fuze is prepared for any desired time of flight by boring through the "side-hole" corresponding to the required time into the composition.

The fuze is fixed in the fuze-hole by screwing it round by hand until it is held firmly in the fuze-hole; it must not be fixed by tapping with a mallet or striking the fuze, previously inserted loosely in the shell, against any hard object. Such action would tend to crack the fuze and cause a premature explosion.

The fuze must not be uncapped until the shell is placed in the muzzle of the gun. This is done by taking hold of the exposed end of the copper band, and unwinding from *right* to *left* smartly, so as to thoroughly detach the band from the head of the fuze, and so leave the priming fully exposed.

Time of burning at rest, 1.6 to 16.5 seconds.

Fuze, Time and Percussion, No. 56, Mark IV.

(Plate IX.)

The fuze consists of the following parts made of gunmetal, except where otherwise stated, viz.:—Body, detonator plug with detonator, percussion pellet, brass spiral spring, base plug, brass safety pellet, brass ball, composition ring, cap, brass washer, dome, two safety pins, and two leather washers.

The *body* is screwed at the lower end to G.S. fuze-hole gauge, and bored from the bottom to receive a percussion pellet and base plug. Two holes are bored beyond the recess for percussion pellet, one for the detonator plug, the other for the safety pellet.

The *detonator plug* is screwed on the outside, and fitted with a detonator, covered with a brass disc. The hole bored for the detonator plug is continued above it to form a small magazine filled with F.G. powder. In the top of the body is bored a recess to contain a perforated pellet of pressed pistol powder, which communicates with the magazine by a hole, bored at right angles to the axis of the fuze. The stem on the body is screwed on top to take the cap, two grooves being cut in the top end of stem to receive the feathers on the brass washer. A groove is cut in the top face of body, close to the stem, and half way round it, and a gas-escape hole bored obliquely through the body into the groove. A small tablet of fine white paper is secured with shellac to the body of the fuze over the perforated powder pellet, and over it, two washers of fine white paper and calf-skin are secured with shellac, a hole being cut through the washers and tablet immediately over the powder pellet.

The *percussion pellet* has a slot in the side for the safety pellet and ball to fall into when set in action. A hole is made transversely through the pellet and fitted with a brass retaining bolt, held in position by a brass spiral spring. The pellet contains a powder charge of F.G. powder. A small set screw, in the wall of the body, fits into a slot in the percussion pellet to prevent it from turning in flight. A spiral spring, of brass wire, is placed between the percussion pellet and detonator plug.

The *base plug* contains a perforated pellet of pressed powder, covered with shallon, and secured by a brass washer spun over on top.

The *safety pellet* has a slot cut in the side to clear the brass ball, and is suspended in the body by a thin copper wire passing through it. A hole is also bored in the upper part of the pellet and body of fuze for the safety pin to pass through.

The *composition ring* has a chamber on one side, and three projections on the inside to keep it concentric with the stem of the body. The chamber has a hammer with a steel needle suspended in it by a copper wire over a patch of detonating composition. A safety pin also passes through the hammer and chamber. The ring has a groove on the underside filled with composition, and connected with the chamber by a lighting hole. The outside of the ring is graduated from 0 to 18, each division being subdivided into halves and quarters, with a broad arrow at the point, where the groove is interrupted by a bridge soldered in.

The *dome* is made of sheet brass.

The *washer* is made of sheet brass, with two feathers which fit into featherways cut in the top of the stem. When screwing up the cap the washers remain stationary, thus preventing the dome from turning and altering the setting of the fuze.

The *cap* is made of gunmetal, hexagonal in form, and screws on the stem of the body.

The fuze is stamped **T** on the composition ring close to the time safety pin, and **P** on the body close to the percussion pin.

The fuze should be set *before* the safety pins are withdrawn.

To set the time arrangement, the cap is loosened with the "key, fuze, universal," and the ring moved round until the graduation ordered is exactly in line with the arrow on the body; the fuze is then clamped by screwing down the cap as tightly as possible, care being taken that the ring and dome have even bearings.

If the fuze is required to act as a percussion fuze only, the **P** pin should be withdrawn and the **T** pin left in position; otherwise, both pins should be withdrawn, but this should not be done till the moment of loading.

Action.—On discharge, if the time safety pin has been withdrawn, the hammer sets back, shearing the suspending wire, and igniting the detonator and the time ring, which burns until it comes over the pellet and so flashes down through the radial magazine, detonator pellet, and base plug, and into the shell.

If the percussion pin has been withdrawn, the safety pellet sets back, shearing the suspending wire, and the base brass ball falls down into the space over the safety pellet. The centrifugal bolt, owing to the rotation of the shell, is withdrawn, the percussion pellet is free to move forward on impact and ignite the detonator, which flashes through the percussion pellet and base plug into the shell.

FIXING PLUGS, FUZES, AND SECURING SHELLS.

When plugs or metal fuzes are screwed into shells they will, unless required for immediate use, be lubricated with a mixture of Mark III luting and mineral jelly, in equal proportions, by weight.

The mixture is to be applied to the threads of the fuze or plug with a brush, in sufficient quantity to cover them, care being taken that it does not extend over the bottom.

A coat of paint of the same colour as the tip of the shell will be applied over the junction of the G.S. fuze-hole plug and shell when the latter is filled. The "turnscrew" on the limber is to be used for starting fuze-hole plugs that may have become jammed or set fast.

TUBE, FRICTION, COPPER, SOLID DRAWN, WITH BALL,
MARK II.*(Plate XI.)*

The tube is made of solid drawn copper, and has a solid head; it is filled with pistol powder, and the bottom is closed by a brass ball, over which is a cork plug, secured by shellac. The length is 2.1 inches. A hole is bored through one side of the tube, having its centre about .25 inch below the top, and through this hole projects a copper nib-piece, with a small hole bored in it to allow the flash to reach the powder in the tube. This nib-piece contained a roughened copper friction bar, which is smeared with a detonating composition of chlorate of potash, sulphur, and sulphide of antimony, and the nib-piece is pinched down upon the friction bar, the projecting part of which has a vertical eye, into which the hook of the lanyard fits. On pulling the lanyard the friction bar is drawn out, igniting the composition and firing tube. The gas from the exploded cartridge drives the tube out of the vent.

RANGE TABLE.

Charge { weight, 3 lb. 3 oz. Projectile, weight 16 lb. 1½ oz.
nature, R.L.G.⁴ Muzzle velocity, 1,355 f.s.

Remaining velocity.	5 minutes elevation or deflection alters point of impact.		Slope of Descent.	Elevation.	Range.	Fuze scale for fuze time and percussion, Mark IV, No. 86.	50 per cent. of rounds should fall in			Time of flight.
	Range.	Laterally or vertically.					Length.	Breadth.	Height.	
f.s.	yd.	yd.	1 in	° /	yd.	1½	yd.	yd.	yd.	secs.
1,243	42	0.43	94	0 7	300	1½	6.3	0.25	0.08	0.76
1,203	42	0.58	67	0 19	400	1½	8.3	0.34	0.13	1.03
1,174	38	0.72	52	0 31	500	2	10.2	0.43	0.20	1.30
1,140	38	0.87	42	0 44	600	2½	12.1	0.52	0.29	1.58
1,110	38	1.01	35	0 57	700	3	13.9	0.61	0.40	1.15
1,084	36	1.16	30	1 10	800	3½	15.7	0.71	0.53	2.86
1,062	36	1.31	26	1 24	900	4	17.4	0.81	0.68	2.44
1,043	36	1.45	23	1 39	1,000	4½	19.1	0.91	0.85	2.73
1,026	36	1.60	20	1 52	1,100	5	20.7	1.02	1.03	3.02
1,010	33	1.74	18	2 6	1,200	5½	22.3	1.13	1.23	3.32
994	33	1.89	16	2 21	1,300	6	23.8	1.24	1.45	3.63
979	33	2.03	15	2 36	1,400	6½	25.2	1.35	1.68	3.94
964	31	2.18	14	2 51	1,500	6½	26.6	1.46	1.93	4.26
950	31	2.32	13	3 7	1,600	7½	28.0	1.58	2.20	4.58
936	29	2.47	12	3 23	1,700	7½	29.3	1.70	2.48	4.90
922	29	2.61	11	3 40	1,800	8½	30.6	1.83	2.78	5.23
909	24	2.76	10	3 57	1,900	8½	31.8	1.96	3.08	5.56
896	28	2.91	9.4	4 13	2,000	9½	33.0	2.09	3.40	5.90
884	28	3.05	8.8	4 33	2,100	9½	34.1	2.22	3.75	6.25
872	26	3.20	8.3	4 51	2,200	10½	35.2	2.35	4.10	6.60
860	25	3.34	7.4	5 10	2,300	10½	36.2	2.48	4.47	6.96
848	25	3.49	7.4	5 30	2,400	11½	37.2	2.62	4.85	7.32
837	25	3.63	7.0	5 50	2,500	12	38.1	2.76	5.25	7.69
826	25	3.78	6.6	6 10	2,600	12½	39.0	2.90	5.77	8.06
815	24	3.92	6.3	6 30	2,700	13	39.8	3.05	6.10	8.44
805	24	4.07	6.0	6 51	2,800	13½	40.7	3.20	6.55	8.82
795	24	4.21	5.7	7 12	2,900	14½	41.4	3.35	7.02	9.21
785	23	4.36	5.4	7 33	3,000	14½	42.1	3.50	7.50	9.60
775	23	4.51	5.2	7 55	3,100	15½	42.8	3.65	8.00	10.00
765	23	4.65	5.0	8 17	3,200	16	43.5	3.80	8.51	10.41
755	23	4.80	4.8	8 39	3,300	16½	44.2	3.96	9.09	10.83
746	23	4.94	4.6	9 1	3,400	17½	44.8	4.13	9.65	11.26
737	22	5.09	4.4	9 24	3,500	18	45.4	4.30	10.22	11.70
728	22	5.23	4.2	9 46	3,600	—	46.0	4.47	10.82	12.14
719	21	5.38	4.0	10 9	3,700	—	46.6	4.65	11.26	12.59
710	21	5.52	3.9	10 33	3,800	—	47.2	4.83	12.10	13.04
701	20	5.67	3.7	10 57	3,900	—	47.8	5.02	12.80	13.50
693	20	5.81	3.6	11 22	4,000	—	48.4	5.22	13.51	13.98
685	20	5.96	3.4	11 47	4,100	—	48.9	5.42	14.30	14.42
677	20	6.11	3.3	12 12	4,200	—	49.4	5.63	15.10	14.88

FUZE SCALE.

15 Sec. Wood Time Fuze. Charge 3 lbs. 3 ozs. R.L.G.⁴

Yards.	Fuze.	Yards.	Fuze.
410	2·0	2,530	16·5
485	2·5	2,600	17·0
560	3·0	2,670	17·5
635	3·5	2,740	18·0
710	4·0	2,810	18·5
785	4·5	2,880	19·0
860	5·0	2,915	19·5
935	5·5	3,010	20·0
1,010	6·0	3,075	20·5
1,085	6·5	3,135	21·0
1,160	7·0	3,200	21·5
1,235	7·5	3,260	22·0
1,310	8·0	3,320	22·5
1,385	8·5	3,380	23·0
1,460	9·0	3,440	23·5
1,530	9·5	3,500	24·0
1,600	10·0	3,560	24·5
1,675	10·5	3,620	25·0
1,750	11·0	3,680	25·5
1,820	11·5	3,740	26·0
1,890	12·0	3,800	26·5
1,965	12·5	3,860	27·0
2,010	13·0	3,920	27·5
2,105	13·5	3,980	28·0
2,175	14·0	4,040	28·5
2,250	14·5	4,100	29·0
2,325	15·0	4,155	29·5
2,400	15·5	4,210	30·0
2,460	16·0		

SECTION GUN DRILL.

Battery gun drill, which does not vary with the equipment, is given in "Field Artillery Drill."

The following paragraphs give the duties of the detachments at the section commander's orders.

Single detachments should be accustomed to drill as if forming part of a section, and the instructor should therefore always use the orders given for the section commander.

On dismantled parades the detachment will form Detachment Rear, where it is laid down for them to mount, and Nos. 6, 7, 8, and 9 will attend to the limbers, No. 6 pushing in rear, Nos. 7, 8, and 9 at the shafts, No. 9 between them, No. 7 at the point of the off, No. 8 of the near shaft.

Batteries practising either with blank cartridges or projectiles should leave their drill shell and cartridges in camp or barracks. The tampeon is not to be placed in the gun except in the gun park.

ARRANGEMENT.

THE DETACHMENT--

To tell off.
 Detachment rear.
 To form detachment rear in action.
 To take post from detachment rear in action.
 Mounted.
 To mount.
 To dismount.
 To move the gun with drag ropes.
 " " without "

PREPARATION FOR ACTION.

ACTION.

DUTIES—

Wagon supply.
 Casualties.
 Signals.

TO LOAD.

TO FIRE—

Miss-fire.

PREPARATION FOR CAVALRY.

MAGAZINE FIRE,

CASE.

TO STAND FAST.

TO CEASE FIRING.

TO LIMBER UP.

INDIRECT LAYING—

One aiming post.

Two " posts.

MOUNTING AND DISMOUNTING—

To dismount the gun and carriage.

To mount " "

DISABLED ORDNANCE—

To replace a damaged wheel.

To remove the gun and carriage by a limber.

To " " " wagon.

METHOD OF DRILLING RECRUITS—

General remarks.

To fire.

To load.

THE DETACHMENT.

On mounted parades, as long as limbered up, No. 1 remains mounted on the left of the leaders—he does not dismount when the *detachment* is ordered to do so.

The detachment consists of nine members, who fall in two deep, one pace between ranks, No. 1 on the right of the front rank.

TO TELL OFF.

<i>Section Commander.</i>		<i>No. 1.</i>
.... Section—Tell Off.		

At the order from the section commander—No. 1 numbers 1; the right hand man of the rear rank numbers 2; the right hand man of the front rank 3; the second man from the right of the rear rank 4; his front rank man 5; and so on.

DETACHMENT REAR.

Formed as above, 3 yards in rear of the gun wheels, No. 1 covering the off wheel.

TO FORM DETACHMENT REAR IN ACTION.

<i>Section Commander.</i>		<i>No. 1.</i>
.... Section—Detachment Rear.		No. Double March.

At the order from the section commander—No. 1 doubles to his place and gives the order "Double March."

At the order from the No. 1—the numbers double into their places on the left of No. 1, each halting as he reaches his place.

TO TAKE POST FROM DETACHMENT REAR IN ACTION

<u>Section Commander.</u>		<u>No. 1.</u>
.... Section—Take Post.		No. Double March

At the order from No. 1—all the numbers double to their places.

MOUNTED.

No. 1 on his horse; 2 and 3 on the gun limber; 4 and 5 on the axletree seats; 6 and 7 on the wagon limber; 8 and 9 on the wagon body; 2, 4, 6, and 8 on the near; 3, 5, 7, and 9 on the off side.

The actual positions of the numbers on the carriages are as follows:—

At the order "Attention"—they sit upright, holding the handstraps with both hands.

At the order "March"—they take hold of the guard irons with their outward hands, and when going over rough ground slightly raise themselves so as to avoid being jolted.

At the order "Sit at Ease"—they drop the handstraps and sit well back, both hands between the thighs.

When a subdivision is without a wagon, No. 6 may on an emergency on service ride between Nos. 2 and 3 when going into action. In this case he will mount and dismount by the front of the limber on the near side.

TO MOUNT.

<u>Section Commander.</u>		<u>No. 1.</u>
.... Section—Detachments, Prepare to Mount—Mount.		

At the order "Detachments prepare to Mount" from the section commander—the numbers double to their places at the carriages; 2 and 6 lay hold of the guard irons with their left, 3 and 7 with their right hands, placing the inner foot on the trail or perch handle; 4 and 8 lay hold of the guard irons with their right hands, placing the right foot on the foot rest or spoke; 5 and 9 lay hold of the guard iron with the left hand, placing the left foot on the foot rest or spoke.

At the order "Mount"—the whole spring into their places. The numbers on the limbers turn round to the front, lifting their feet close together and throwing them over the guard irons; the numbers on the axletree seats turn outwards.

TO DISMOUNT.

<u>Section Commander.</u>		<u>No. 1.</u>
.... Section—Detachments, Prepare to Dismount—Dis- mount.		

At the order "Detachments Prepare to Dismount" from the section commander—Nos. 2, 3, 6, and 7 turn to the rear, throwing their legs over the guard irons; Nos. 4 and 5 place their inner hands on the

gun and their feet in front of the foot rests; the other numbers stand up, keeping their outer hands on the guard irons.

At the order "Dismount"—the whole jump off and form detachment rear.

TO MOVE THE GUN WITH DRAG ROPES.

<u>Section Commander.</u>		<u>No. 1.</u>
.... Section—with drag ropes, Prepare to Advance.		

At the order from the section commander—Nos. 2 and 3 hook the drag ropes to the gun wheel washers, the three highest numbers go to the shafts, and the remainder man the ropes.

TO MOVE THE GUN WITHOUT DRAG ROPES.

<u>Section Commander.</u>		<u>No. 1.</u>
.... Section—without drag ropes, Prepare to Advance.		

At the order from the section commander—Nos. 2 and 3 push between the muzzle and wheels; Nos. 4 and 5 man the gun wheels; the three highest numbers go to the shafts; No. 6 pushes at the point of the splinter bar on the near side; No. 1 assists if necessary.

PREPARATION FOR ACTION.

<u>Section Commander.</u>		<u>No. 1.</u>
.... Section—Prepare for Action.		

At the order from the section commander—the detachment dismount, and—

No. 1 sees that the bore is clear, and superintends the other numbers.

No. 2 examines the axletree box, removing the covers from the cartridges.*

No. 3 fills the tube pocket and examines the vent and axletree box, removing the covers from the cartridges.*

No. 4 examines the sights and elevating gear.

No. 5 sees that the fuze key is in its pocket, and examines the limber boxes.

The wagon numbers examine the wagon boxes.

On the completion of the above the detachment mount without further order.

The numbers detailed to "examine" the various ammunition boxes see that they are properly filled, also that the lids open easily, and the locks are in good order. Any deficiencies in the limber boxes are filled up from the wagon body under the direction of the No. 1.

* At drill the covers need not be removed from the cartridges.

ACTION.

<i>Section Commander.</i>	<i>No. 1.</i>
.... Section—Action front.	No.... Action Front.

At the order from the No. 1—

The detachment dismount, and No. 3 unkeys, and with No. 2 lifts the trail; when the trail is clear of the hook No. 3 gives "Limber drive on."

Nos. 2 and 3 carry the trail round half a circle to the left, No. 2 shifting round the trail eye to avoid walking backwards, and lower it to the ground.

Nos. 4 and 5 man the wheels.

The limber moves as detailed in "Field Artillery Drill."

As soon as the trail has been lowered to the ground—

No. 1 ships the handspike, lays for direction, and points out the target to No. 4.

No. 2 receives the sponge from No. 4, and remains facing the gun with the sponge stave in his right hand, rammer head on the ground to the rear.

No. 3 takes the lanyard out of the tube pocket, and places it round his neck, the hook end hanging down on his right side.

No. 4 unbuckles the sponge and throws it over to No. 2, sets his sight as ordered, and lays for elevation. As soon as the gun is loaded and laid he holds up his hand; he should remain in position until the signal "make ready" is given, but should not weary his eye by looking over the sights.

No. 5 prepares to issue ammunition; if wagon supply is ordered he takes post 10 yards in rear of the gun until the arrival of the wagon.

No. 6 assists No. 5.

The positions of the numbers are as follows:—

No. 1 one yard in rear of the trail eye.

No. 2 facing the gun, outside of and in line with the front of the right wheel.

No. 3 close to and facing the breech on the left side.

No. 4 on the right of the trail eye.

No. 5 in the rear of the limber on the off side.

No. 6 in rear of the limber on the near side.

Action right, left, or rear, is the same except that at—

Action Right.—The trail is carried round a quarter of a circle only.

Action Left.—The trail is carried round a quarter of a circle to the right, No. 3, in this case, shifting round the trail eye.

Action Rear.—The trail is not carried round.

The limber in all cases moves as detailed in "Field Artillery Drill."

DUTIES.

No. 1

Commands, attends to the handspike, sees that the time fuzes have been bored or set correctly, and lays for direction.

He is responsible for the entire service of his gun.

While in action he must see that the gun is kept in the general alignment of the battery.

Should it be necessary for No. 1 to leave the handspike, No. 3 will take his place there as soon as the loading is completed, in addition to his own duties.

Should a case arise in which it is necessary that No. 1 should lay, he will perform the duties of No. 4, with the addition of "commands, and sees that the time fuzes have been bored or set correctly," No. 4 performing No. 1's duties with the above exceptions.

He lays for direction by looking along the line given by the cascable and muzzle while standing at the end of the handspike, not by looking over the sights. When, however, great accuracy of line is of importance, the laying for direction will be done by No. 4, in which case No. 1 will traverse according to No. 4's signals.

He only gives the words of command shown for him; he does not repeat the section commander's orders. His executive orders should be no louder than is necessary for his subdivision to hear.

No. 2

Sponges, rams home, and mans the wheel.

He sponges and rams home as follows:—

He takes an oblique pace first to the right with his right foot, then to the left with his left, then a side pace of 30 inches to his right, at the same time bringing the sponge stave horizontal, sponge head towards the gun; he then enters the sponge head into the bore, shifts his left hand, back under, to the right, straightens his right knee, forces the sponge up the bore until his hands meet the face of the piece, shifts his hands to the rammer head, and forces the sponge hard home, bending over the left knee. He then gives the sponge two half-turns by first lowering his wrists and then raising them, at the same time pressing the sponge against the bottom of the bore. He next draws the sponge out about half its length, at the same time straightening the left knee and bending over on his right; then again bending over the left knee, and shifting his hands to the centre of the stave, he bends outwards, withdrawing the sponge, and, with the left hand close to the head, turns the sponge, keeping the right hand fast, but turning the wrist, and throwing the sponge head upwards with the left hand, with which he seizes the stave at the rammer head.

When No. 6 has put in the charge, uncapped the fuze, or removed the safety pin or pins, No. 2 introduces the rammer head, brings his hands to the sponge head, and forces the charge home in one motion, throwing in the weight of his body, both arms extended as far as possible so as to keep his body clear of the muzzle. Directly the charge is home he springs the rammer by jerking it out with his right hand, and allowing the stave to slide through his hand, he grasps it firmly in the middle with the right hand, and at the rammer head with the left, both knees straight; steps back outside the wheel, first with his right foot, then with his left, and brings the right heel to the left; he brings the sponge stave to the slope, and the left hand to the side in the first motion of stepping back, and remains facing the gun.

No. 3

Attends to the vent, fires, and mans the wheel.

He serves the vent as follows:—

He places his right thumb on the vent, keeping his elbow raised and his fingers on the right side of the gun.

No. 4

Supplies No. 2 with the sponge and replaces it on the trail, lays for elevation, and lifts at the handspike in running up or back.

He must keep the gun layed for elevation, whether loaded or not; he must remember to look over the sights after the loading is completed, to see that the gun has not been shifted. He must always depress last.

As a general rule the whole of the laying for direction will be done by No. 1, but when great accuracy of line is of importance No. 4 will lay for direction also, using the signals given below.

If through casualties there are no non-commissioned officers left in the detachment, No. 4 will "command and see that the time fuzes have been correctly bored or set," in addition to his other duties.

No. 5

Fuzes shell, boring or setting time fuzes. At "Magazine Fire" he will, alternately with No. 6, supply single rounds of ammunition.

No. 6

Brings up ammunition, shows time fuzes to No. 1, loads from left side of muzzle, uncaps or removes safety pins, and assists No. 5.

He carries the cartridge in his right hand, covered by his left arm, the shell in his left hand, covered by his right arm. In loading, the backs of both hands should be down, and No. 6 must be careful that the choked end of the cartridge is next the base of the shell, and that the seam does not come under the vent.

The cartridge should be kept covered until the sponge is out of the bore.

When firing at a moving target, the second round of time shrapnel, having been prepared at the limber or wagon, is at once taken up by No. 6, and shown by him to No. 1, No. 6 then stands ready to load on receipt of No. 1's order.

Except when it is otherwise ordered the numbers work on their own sides of the gun, even numbers on the right side, odd numbers on the left.

NOTE.—On no account should a fuze without a safety pin be placed in any ammunition box.

WAGON SUPPLY.

One wagon for each section is brought up as detailed in "Field Artillery Drill."

As soon as the wagon halts, the Nos. 5 of the two guns of the section go to the wagon body and issue ammunition to their respective guns as above detailed.

The numbers brought up on the wagon—the Nos. 6 of the two detachments as a rule—first unhook the wheel horses, and then perform the duties detailed for No. 6 to the two guns of the section, the numbers on the off side of the wagon to the right gun, those on the near side to the left gun.

At standing gun drill without wagons, Nos. 7, 8, 9 stands 5 yards in rear of the limber.

CASUALTIES.

The captain is responsible for the replacement of casualties as directed in "Field Artillery Drill." Section commanders order such changes of duties in their sections and detachments as they consider necessary.

If the full detachments cannot be maintained, the duties are divided as follows:—

With five numbers, No. 2 performs the duties of No. 6 in addition to his other duties, resting the sponge against the gun while doing so.

With four numbers, No. 1 performs the duties of Nos. 1 and 3, No. 2 performs the duties of Nos. 2 and 6, No. 3 performs the duties of No. 5.

SIGNALS.

Nature.	By whom given.	Meaning.
Either hand raised above head	No. 4	My gun is layed.
Motions with either hand in the required direction, arm well back ..	No. 4*	Trail right, or left.
Drops his hand	No. 4*	Halt (traversing).
Points to the vent with his right hand..	No. 1	Make ready.

TO LOAD.

<u>Section Commander.</u>	<u>No. 1.</u>
... Section—Shrapnel— Fuze—Load.†	No. . . . Shrapnel— Fuze—Load.†

At the order from the No. 1.—

No. 2 sponges, and as soon as No. 6 has removed the safety pin rams home.

No. 3 serves the vent until No. 2 has sprung the rammer, when he hooks a tube to the lanyard, and holds it with the tube in his right hand the lanyard in his left, facing the front.

No. 5 supplies No. 6 with the ammunition ordered, fuzeing shell and setting or boring time fuzes.†

No. 6 receives the ammunition from No. 5, shows time fuze to No. 1, loads, uncaps or removes safety pin or pins, and then doubles back to the limber.

TO FIRE.

No gun is ever to be fired without an *order* from the No. 1, and the No. 1 must never give this order until he has received the order from the section commander and seen that the gun is in proper condition.

<u>Section Commander</u>	<u>No. 1.</u>
Fire No. . . . Gun.	Points to the vent. No. . . . Fire.

At the order from the section commander—No. 1 steps clear of the recoil to the left and points to the vent with his right hand.

* Only when great accuracy of line being required, the laying for direction is done by No. 4.

† "Percussion shrapnel load" or "common load." A percussion fuze is always used with common, unless otherwise ordered.

‡ With wooden fuzes, No. 5, after boring, only places them loosely in the shell, and No. 6 takes them out of the shell to show to No. 1. After No. 1 has examined the fuzes No. 6 fixes them.

At the Signal from the No. 1—

No. 3 places the tube in the vent, steps outside the wheel, and stands facing to the front, holding the lanyard tight with his left hand, the forearm across the body, and the elbow so bent that the hand is level with the vent.

No. 2 steps to his left in line with the axle.

No. 4 removes the sight and steps clear of the recoil.

As soon as he sees No. 3 ready and the other numbers clear No. 1 gives the order "No. . . . Fire."

At the order from the No. 1—

No. 3 slews his body to the left, and thus fires the gun; he then places the lanyard round his neck, the hook end hanging down on his right side.

Directly the gun stops in its recoil it is run up to its previous position without any order.

No. 1 assists if he considers it necessary.

Nos. 2 and 3 man the wheels.

No. 4 lifts at the handspike.

At battery and section fire No. 6 brings up another round, but does not load until the order is given.

As soon as the gun is run up—

No. 1 lays for direction.

No. 4 lays for elevation.

In addition when using drill ammunition without further order—

Nos. 1 and 4 raise the trail until the drill ammunition falls out.

Nos. 2 and 3 man the wheels. No. 3 removes the drill tube.

No. 6 doubles up, picks up the drill ammunition, and returns it to the limber or wagon.

MISS-FIRE.

If there is a miss-fire No. 3 goes round to the front of the axle-tree, and from there takes out the old tube and puts in a fresh one, and then resumes his position. The gun is fired when ordered.

PREPARATION FOR CAVALRY.

<i>Section Commander.</i>		<i>No. 1.</i>
.... Section—Prepare for Cavalry.		

At the order from the section commander—

Nos. 5 and 6 fuze three shrapnel, setting the fuzes at 2,* and fix them. They place these shell together on the ground behind the limber.

MAGAZINE FIRE.

<i>Section Commander.</i>		<i>No. 1</i>
.... Section—Magazine Fire.		

* With wooden fuzes, fuze 3.

At the order from the section commander—

No. 4 lays for elevation by placing two fingers over the tangent sight,* which is run down in its socket.

The guns are reloaded with shrapnel fuze 2† as soon as fired without any further order.

Nos. 5 and 6 perform the duties of No. 6 alternately, so that directly the gun has been sponged one of them may be ready to reload.

The gun is not run up between rounds unless necessary.

Nos. 5 and 6 should not show the time fuzes to No. 1.

CASE.

Section Commander.

No. 1.

.... Section—Case.

This is the same as above, substituting case for shrapnel fuze 2. No. 6 will double up and obtain the case shot from the axletree boxes. As soon as the last case shot has been supplied Nos. 5 and 6 alternately load shrapnel reversed without fuze or plug.

TO STAND FAST.

Section Commander.

No. 1.

.... Section—Stand Fast.

At the order from the section commander—

All stand fast, whatever they are doing, except that No. 3 removes the tube if it is in the vent.

At the order "Go on" the work is continued.

TO CEASE FIRING.

Section Commander.

No. 1.

.... Section—Cease Firing.

At the order from the section commander—

No. 1 straps the handspike on the trail.

No. 2 throws the sponge over to No. 4.

No. 3 replaces the lanyard in the tube pocket.

No. 4 straps the sponge on the trail, lowers the sight, if necessary, and clamps it.

Nos. 5 and 6 replace in the limber or wagon the ammunition, removing the fuzes and screwing in the plugs.

Note.—If for any reason it is impossible to fire the guns at "Cease Firing," and the guns cannot be left in their position, the battery com-

* As in most cases the left tangent sight will be already run down in its socket, time will be saved by using it.

† With wooden fuzes, fuze 3.

mander may order them to be unloaded. This is done as described for drill ammunition, but great care must be taken. The shell should be received by hand at the muzzle by No. 6, and not allowed to drop on the ground.

In cases where the time pin has been taken out before the order "Cease Firing" is given, the loading will be completed and the gun fired as if it had been loaded when the order was given.

TO LIMBER UP.

<i>Section Commander.</i>	<i>No. 1.</i>
.... Section—Front Limber Up.	

At the order from the section commander—

Nos. 2 and 3 carry the trail round half a circle to the right, No. 2 shifting round the trail eye to avoid walking backwards, and lower it to the ground.

Nos. 4 and 5 man the wheels.

As soon as the trail is lowered the numbers get under cover—

No. 1 in front of No. 2;
 Nos. 2 and 3 between breech and wheels;
 Nos. 4 and 5 " muzzle " ;
 No. 6 in front of No. 4;

the whole with their backs to the axletree.

The limber comes up as detailed in "Field Artillery Drill," and No. 1 gives "Halt, Limber Up."

At the order from the No. 1—

Nos. 2 and 3 lift the trail and place it on the hook.

No. 3 keys up.

Nos. 4 and 5 man the wheels.

On the completion of the above, the detachment mount without further order.

Right, left, or rear limber up is the same except that at—

Right Limber Up—the trail is carried round a quarter of a circle only.

Left Limber Up—the trail is carried round a quarter of a circle to the left, No. 3 in this case shifting round the trail eye.

Rear Limber Up—the trail is not carried round.

The limber in all cases moves as detailed in "Field Artillery Drill."

INDIRECT LAYING.

Aiming posts should be issued in pairs of the same colour, the right guns of sections having red; the left, blue. They should be planted with their coloured sides towards the guns, except when, owing to light, &c., the section commanders order the white sides.

ONE AIMING POST.

<i>Section Commander.</i>	<i>No. 1.</i>
.... Section—One Aiming Post.	

At the order from the section commander—

No. 1, standing at the end of the handspike, directs No. 4, by signal, to plant his aiming post in line with the target.

Nos. 2 and 3 mark on the ground the position of the wheels.

No. 4 doubles out about 50 yards to the front with one aiming post, which he plants as directed by No. 1; he then doubles back and gets out his clinometer.

At "Go on" the firing is continued, the gun being layed for direction on the aiming post, and for elevation by clinometer.

When the target cannot be seen by the No. 1 dismounted, the section commander will direct whether he should mount or stand up on the limber.

TWO AIMING POSTS.

<i>Section Commander.</i>		<i>No. 1.</i>
... Section—Two Aiming Posts.		

At this order from the section commander which is given when the battery is halted under cover previous to occupying a position by the deliberate method—

No. 4 gets out his clinometer and aiming posts.

As soon then as the battery commander gives the signal (*see* "Field Artillery Drill"), the section commanders and layers fall out in the usual way, but each layer carries his two aiming posts and clinometer instead of tangent sight.

The battery commander, after pointing out the target, shows the position of the front post of the directing gun, the layers of the remaining guns extend along the alignment and plant their front posts at the interval ordered.

Each layer, as soon as he has planted his front post, doubles a short distance to the rear and plants his second post in line with the target and the front one. He then takes up a position for his gun out of sight of the target and in line with his two posts, looking to the directing gun for his dressing.

The section commanders see that the layers are properly placed before they double back to the battery.

Then when the battery commander gives the signal to advance the battery is brought into action as detailed in "Field Artillery Drill" (Chapter III, Section 8 (ii)). As, however, it is very important that the guns should be brought exactly into line with the two posts, it will usually save time if the battery is advanced at a walk and in such a manner that the guns may be brought into action "right" or "left." Nos. 2 and 3 mark on the ground the positions of the wheels.

After the first round the gun is layed for direction on the near aiming post only.

MOUNTING AND DISMOUNTING.

This should only be practised at the annual course of military training, and then only sufficiently for instruction: every care must be taken that the equipment is not injured.

TO DISMOUNT THE GUN AND CARRIAGE.

<i>Section Commander.</i>	<i>No. 1.</i>
Dismount No. . . . Gun and Carriage.	No. . . . Prepare to Dismount the Gun. Dismount the Gun. Dismount the Carriage. Lift—Lower.

At the order "Prepare to Dismount the Gun"—
No. 1 disconnects the elevating gear, runs it up, throws it back.
Nos. 2 and 3 remove the capsquares and the inner stanchions of the guard irons and man the wheels.

No. 4 removes the sights.
Nos. 4 and 5 make fast two drag ropes with a reef knot, half over and half under the cascable, and pass the ends to the front. Nos. 4 and 5 then man the trail handles.

Nos. 6 and 7 bring up the drag ropes to Nos. 4 and 5, and then man the ropes.

Nos. 8 and 9 man the ropes.

At the order "Dismount the Gun"—

Nos. 1, 4, and 5 raise the trail until the muzzle touches the ground; Nos. 2 and 3 man the wheels forward; Nos. 6, 7, 8, and 9 haul the gun out of the trunnion holes, steadying it when perpendicular. Care must be taken that no number gets between the gun and carriage.

As soon as the gun is steady, No. 1 gives "Lower the Trail" and "Run back," and the carriage is run out of the way by Nos. 2, 3, 4, and 5, who then immediately man the ropes. No. 1 then gives "Lower the Gun," and the gun is lowered gently for about one-third of the distance and then allowed to fall to the ground (straight, to avoid injury to the sight clamps) by all the numbers walking forward with the drag ropes.

At the order "Dismount the Carriage"—

Nos. 2, 3, 4, and 5 go to the carriage; Nos. 2 and 3 in rear, 4 and 5 in front.

Nos. 6, 7, 8, and 9 go to the wheels; Nos. 6 and 7 in front, 8 and 9 in rear.

Nos. 8 and 9 take off the lynch pins and washers.

*At the order "Lift"—*the carriage is lifted and the wheels taken off.

*At the order "Lower"—*the wheels are placed on the ground, dish down, and the carriage is lowered to the ground.

TO MOUNT THE GUN AND CARRIAGE.

<i>Section Commander.</i>	<i>No. 1.</i>
Mount No. . . . Gun and Carriage.	No. . . . Mount the Carriage. Lift. Prepare to Mount the Gun. Mount the Gun.

This is exactly opposite to the dismounting just described.
A handspike is placed under the cascable, and the drag ropes are given a turn round it, the running ends coming off below. To raise

the gun, Nos. 1, 2, 3, 4, and 5 lift at this handspike, No. 1 in the centre, while 6, 7, 8, and 9 haul on the ropes. Four extra numbers should assist by lifting at a handspike placed under the gun, just in rear of the trunnions.

Note.—Limbers and wagons are mounted and dismounted in a similar way, the shafts having been previously removed.

DISABLED ORDNANCE.

Whenever operations are not described in detail or numbers are not told off to particular duties, the No. 1 will order such duties to the several numbers as may be required.

TO REPLACE A DAMAGED WHEEL.

Should a gun wheel be disabled in action, it should be immediately turned so as to bring the sound portion on to the dragshoe, and, if necessary, lashed, and notice should be sent to the captain.

The latter will immediately send up another wheel, which will be brought alongside the damaged one, and the wheels changed as follows:—

<i>Section Commander.</i>		<i>No. 1.</i>
No. Change Wheels.		No. Change Wheels.
		Lift.
		Lower.

At the order "No. Change Wheels," from the No. 1—

Nos. 1 and 6 go to the damaged wheel, No. 1 in rear, No. 6 removes the linch pin and washer.

Nos. 2, 3, 4, and 5 man the traversing handspike, which is placed under the axletree by No. 2 or 3 (according to side).

At the order "Lift"—

The axletree is lifted and the damaged wheel is taken off; No. 6, rolls it out of the way, and the new wheel is put on by the numbers who brought it up.

At the order "Lower"—

The carriage is lowered, the linch pin and washer put on by No. 6, the handspike replaced by No. 2 or 3, and all resume their duties in action.

The damaged wheel is either left on the ground or removed by the numbers who brought up the new one, as the captain may have directed.

In removing wagon wheels the lifting jack should be used.

TO REMOVE THE GUN AND CARRIAGE BY A LIMBER.

The gun is dismounted, the horses taken out; the limber is run over the gun so that the breech is towards the shafts, and the trunnions under the limber hook; the muzzle and the shafts are raised, and the gun slung with a drag rope round the trunnions to the limber hook; the end is passed to the front, and the muzzle borne down, a half hitch is taken round the cascable and made fast to the centre futchell.

The carriage is dismounted, elevating gear removed, and turned over by all the numbers with the trail towards the shafts. It is then

lifted, trail first, up the front of the limber on to the top of the boxes, until the weight is balanced for draught.

The trail is secured by a drag chain to a handspike in the bore, the sidearms are strapped to the trail, the wheels are placed, dish down, on top of the carriage, securely lashed with drag ropes to the box handles in rear, and to the splinter bar in front.

TO REMOVE THE GUN AND CARRIAGE BY A WAGON.

The gun is slung to a limber as before. The carriage is turned over and the trail rested on the rear footboard of the wagon. It is then lifted by all the numbers on to the wagon body until the trail-eye nearly touches the limber boxes, it is secured to the perch by the drag chain. The wheels are placed, dish down, on the top of the carriage and lashed to the box handles.

METHOD OF DRILLING RECRUITS.

GENERAL REMARKS.

Many good recruits are acquainted only with the commonest English words, and as their duties and the materials they have to use are altogether new and strange, instructors should be careful—

To use the simplest language possible.

To explain as they occur, all technical terms.

To illustrate descriptions by means of a piece of chalk or otherwise, and in all cases to render clear the objects of the various duties.

Not to attempt to teach recruits elaborate descriptions, exact measurements, &c., which they do not understand.

To avoid needless repetitions, or wearying the men by keeping them for a long time at one thing; the drill should be varied by short descriptions (avoiding manufacturing details), setting fuzes, &c.

To bring men forward by successive steps, by explaining a position and then doing it; for instance, when commencing recruits' gun drill, the instructor should himself show how a duty should be performed, and then cause every man in turn to do that duty (make every man do No. 1's duty, then every man No. 2's, then No. 4's, and so on). When each man knows the duties of each post separately, the numbers who work and move together should be instructed after the manner described below, before commencing gun drill in quick time.

Great patience is necessary on the part of the instructor. He must make allowance for the different capacities of the recruits, and squads should periodically be arranged so that the intelligent soldier may reap the advantage of his work, and not be kept back by those of inferior ability. Recruits as they progress should be called out in turn to drill, for this gives a man confidence, helps him to learn, and causes him to take an additional interest in his work.

The instructor should place himself where he can be seen and heard by all in the squad; he should stand in a smart soldier-like attitude, and should avoid pacing up and down, looking down on the ground, turning his back on the squad, and similar habits, which have the effect of fidgeting the men and distracting their attention.

His explanation should be given in a distinct voice; his word of command should be sharp and decisive.

Stress is laid on the above points, because men unconsciously imitate their instructors. A first rate instructor will make a good

detachment; his manner and style are, therefore of the first importance.

The utmost alertness of attitude and smartness of movement should be enforced throughout gun drill.

The instructor can at any time ascertain that each number is at his post, by proving. This he does by calling out "*Prove your numbers—No. 1, No. 2, &c.*" The man called upon raises his right hand, and extends it smartly to the front, hand open, thumb uppermost, hand as high as the shoulder. When the next number is called, he drops his hand. The last number lowers his hand at the word "*Down.*"

If at any time the instructor wishes to change the numbers, he gives the order, "*Change Rounds.*" On this, No. 1 becomes 9; 9, 8; 8, 7; 7, 6; 6, 5; 5, 4; 4, 3; 3, 2; 2, 1.

The following is only an example of how the drill should be taught; the details of the other operations should be divided up in a similar manner.

TO FIRE.

At the order "*Fire No. . . . Gun*" from the section commander—
No. 1 steps clear of the recoil to the left, and points to the vent with his right hand.

At that signal—

No. 3 places the tube in the vent, steps outside the wheel, &c.

No. 2 steps to his left in line with the axle.

No. 4 removes the sight and steps clear of the recoil.

No. 1—" *Fire No. . . . Gun.*"

As soon as No. 1 sees No. 3 ready, and the other numbers clear, he gives "No. . . . Fire."

At that order—

No. 3 slews his body to the left, and thus fires the gun; he then places the lanyard round his neck, &c.

" *Go on.*"

Next explain that directly the gun has ceased recoiling, it is run up to its previous position without any further orders.

No. 1 assists, if he considers it necessary.

Nos. 2 and 3 man the wheels.

No. 4 lifts at the handspike.

At battery and section fire, No. 6, &c.

Nos. 1, 2, 3, 4, and 6—" *Go on.*"

Next explain—

As soon as the gun is run up.

No. 1 lays for direction.

No. 4 lays for elevation.

Nos. 1 and 4—" *Go on.*"

Next give—

In addition when using drill ammunition, without further order, the gun must be unloaded.

Nos. 1 and 4 raise the trail until the drill ammunition falls out.

Nos. 2 and 3 man the wheels. No. 3 removes the drill tube.

No. 6 doubles up, picks up the drill ammunition, and returns it to the limber or wagon.

Nos. 1, 2, 3, 4, and 6—" *Go on.*"

TO LOAD.

On the command “. . . . *Section—Shrapnel—Fuze—Load*” from the section commander—

No. 1 gives the order to his detachment.

“*No. . . . Shrapnel—Fuze—Load.*”

No. 3 serves the vent until No. 2 has sprung the rammer, &c.

“*No. 3 Load.*”

No. 2 takes an oblique pace to the right, with his right foot,* then to the left with his left,* then a side pace of 30 inches to his right, at the same time bringing the sponge stave horizontal, sponge head towards the gun;* he then enters the sponge head into the bore,* shifts his left hand back under to the right,* straightens his right knee, and forces the sponge up the bore until his hands meet the face of the piece,* shifts his hands to the rammer head,* and forces the sponge hard home, bending over the left knee.* He then gives the sponge two half turns by first lowering his wrists and then raising them, at the same time pressing the sponge against the bottom of the bore.* He next draws the sponge out about half its length, at the same time straightening the left knee, and bending over on his right;* then again bending over the left knee, and shifting his hands to the centre of the stave, he bends outwards, withdrawing the sponge,* and with the left hand close to the head, turns the sponge, keeping the right hand fast, but turning the wrist, and throwing the sponge head upwards with the left hand, with which he seizes the stave at the rammer head.*

“*No. 2 Load.*”

No. 5 supplies No. 6 with the ammunition ordered, fuzing shell, and boring or setting time fuzes.

“*No. 5 Load.*”

No. 6 receives the ammunition, &c.

“*No. 6 Load.*”

Now go back to No. 2, starting with :—“When No. 6 has put in the charge, uncapped the fuze, or removed the safety pin or pins, No. 2 introduces the rammer head, brings his hands to the sponge head, and forces the charge home in one motion, throwing in the weight of his body, both arms extended as far as possible, so as to keep his body clear of the muzzle”—here give “*No. 2, Go on.*” Then continue No. 2’s duties, thus :—“Directly the charge is home he springs the rammer by jerking it out with his right hand; and allowing the stave to slide through his hand, he grasps it firmly in the middle with the right hand, and at the rammer head with the left, both knees straight;* he then steps back outside the wheel, first with his right foot, then with his left, and brings the right heel to the left; bringing the sponge stave to the slope, and the left hand to the side in the first motion of stepping back. He then remains facing the gun.

* This detail should be given with a distinct pause at each point marked by an asterisk, so as to admit of the recruit carrying out in successive motions the detail given; thus simplifying a lengthy detail.

INSTRUCTIONS FOR USING THE CLINOMETER.

To read the angle marked on the drum.—The brass drum is marked in degrees, commencing at 0° on the top to 45° at the bottom. Each degree is subdivided into 12 parts; each small division, therefore, represents angles of 5 minutes.

The scale is read from right to left, thus—

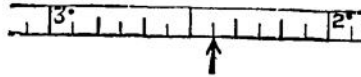

the reading opposite the arrow would indicate an angle of $2^\circ 25'$.

To lay a gun for elevation.—Unscrew the drum until \uparrow points to the elevation required, place the clinometer on the planed portion of the breech, or against the muzzle, thus—

FIG. I.

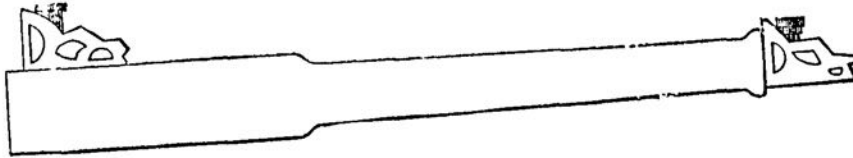

and elevate the piece until the bubble of the spirit-level is in the centre of the tube.

For angles of depression.—Proceed as above, but reverse the direction of the instrument, thus—

FIG. II.

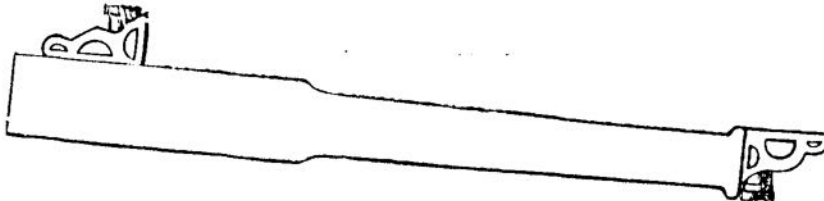

“To measure the angle of sight.”—Lay the gun, with tangent or telescopic sight set at zero, on the object, then measure the angle at which the gun stands by clinometer.

RANGE-FINDER, WATKIN, FIELD.

These range-finders are issued to movable armament as approved from time to time. The instrument will be issued complete with all its appurtenances, except the picket buckets. A history sheet, in duplicate, will be prepared for each range-finder, and every transaction connected with the instrument will be entered on these sheets, as shown on the specimen, page 37. One copy will accompany the instrument to which it relates on all occasions of inspection or return to store; the other will be retained by the Chief Inspector of Position-Finding.

The instrument and equipment will be in charge of the Officer Commanding Royal Artillery, at the place of issue, who will be responsible that the instruments are not made use of by uninstructed non-commissioned officers, and that the general rules for their care and preservation, contained in the "Manual of Field Range-Finding," are attended to.

Demands will be put forward as a rule every two years for the exchange of the range-finding equipment for the purpose of being inspected by the Instructor in Range-Finding.

16-PR. R.M.L. CARRIAGE AND LIMBER.
MOVABLE ARMAMENT.

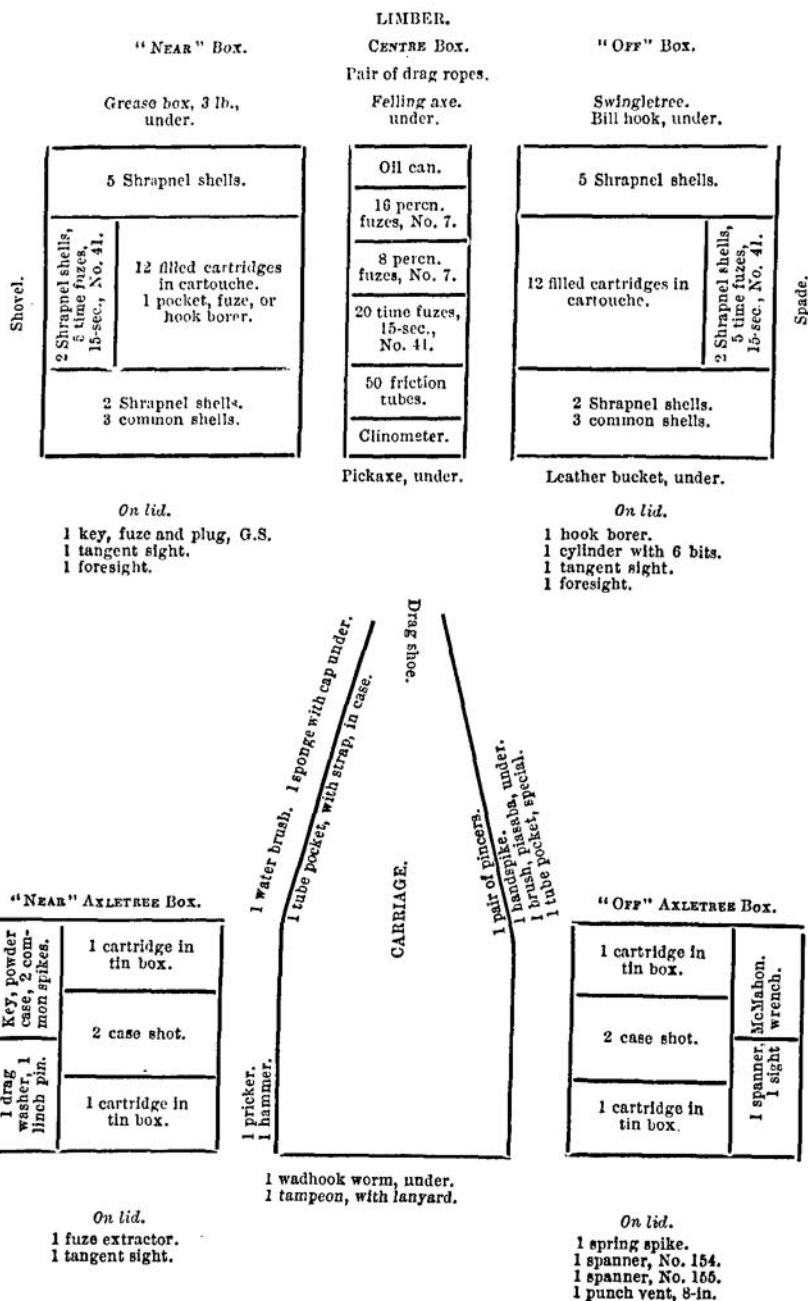

NOTE.—A little oakum may be used with advantage to prevent the movement of the time-fuze cylinders in ammunition and centre boxes, and case shot in axletree boxes.

16-Pr. R.M.L. WAGON AND LIMBER.

MOVABLE ARMAMENT.

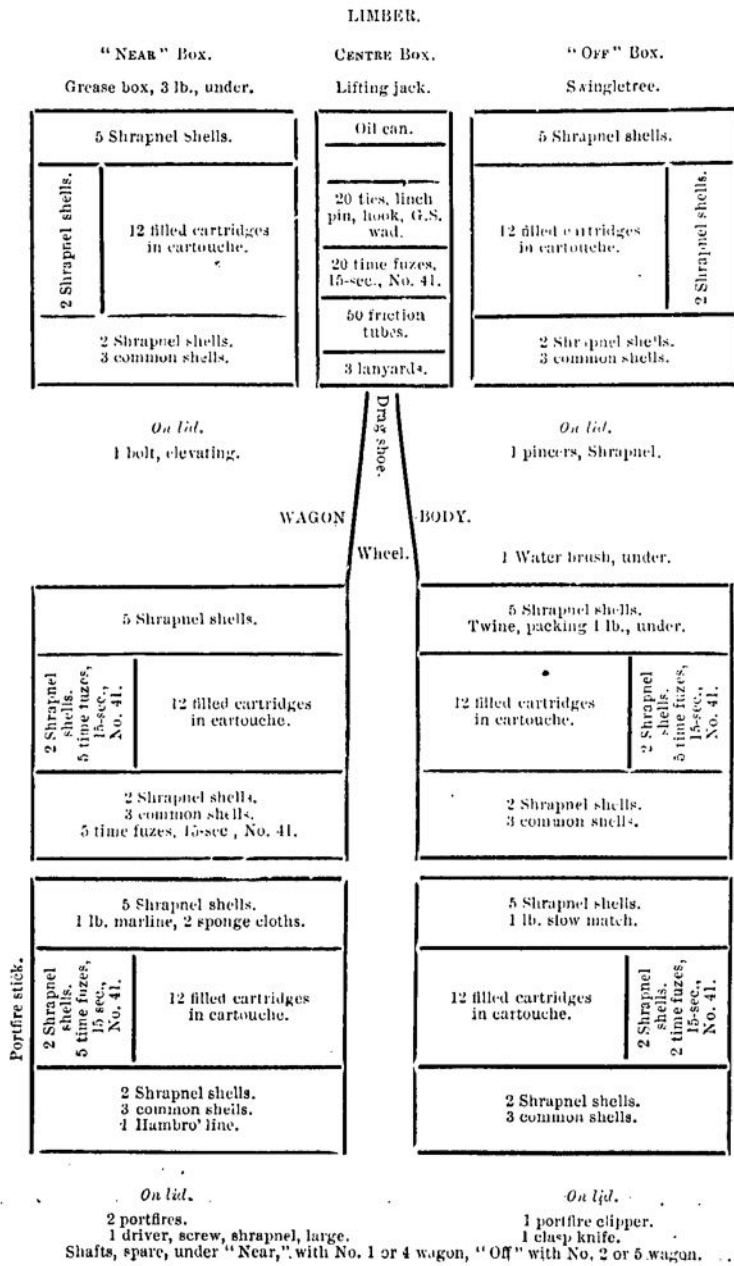

16-Pr. R.M.L. CARRIAGE AND LIMBER.
BATTERIES OF POSITION, VOLUNTEER ARTILLERY.

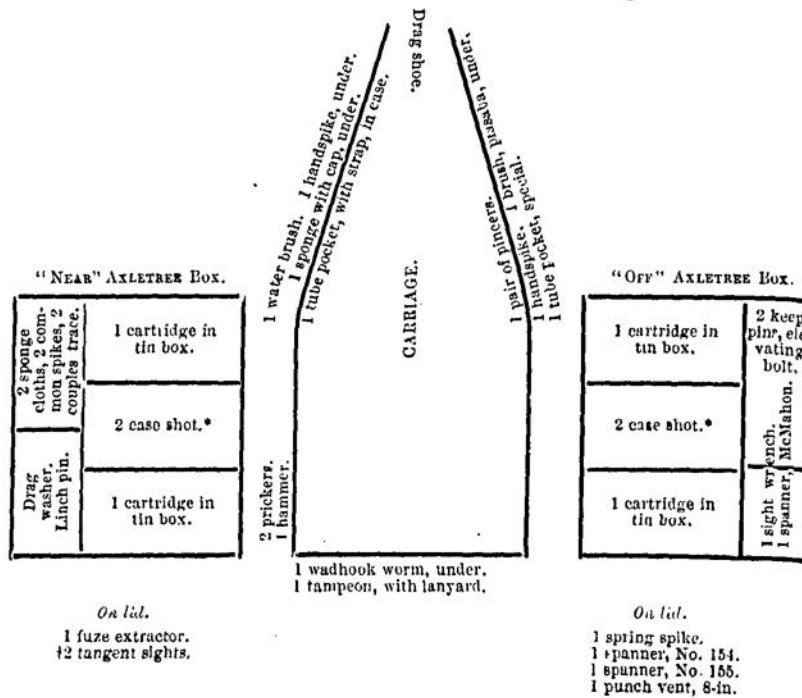
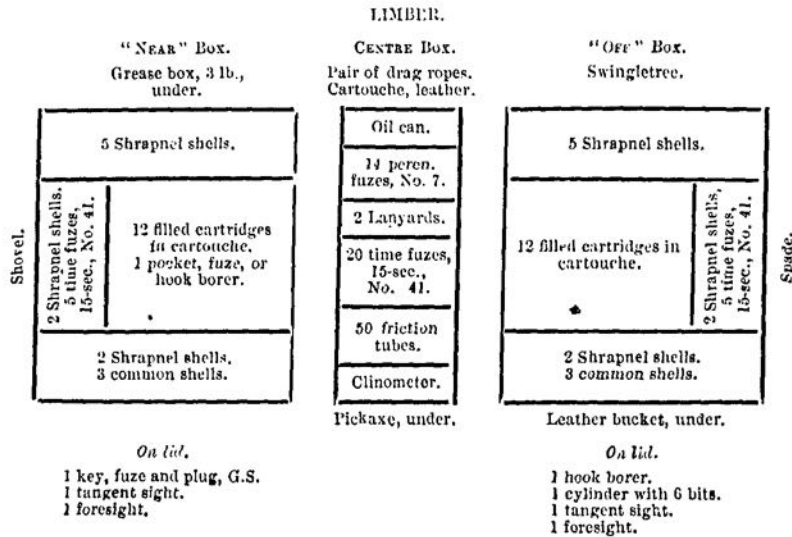

* 2 shells can be carried when required, by removing the wood block and placing it in the corner compartment.
† Carried in No. 1 subdivision.
NOTE.—A Bilbo oakum may be used with advantage, to prevent movement of fuze cylinders in the ammunition and centre boxes, and case shot in axletree boxes.

16-Pr. R.M.L. WAGON AND LIMBER.
BATTERIES OF POSITION, VOLUNTEER ARTILLERY.

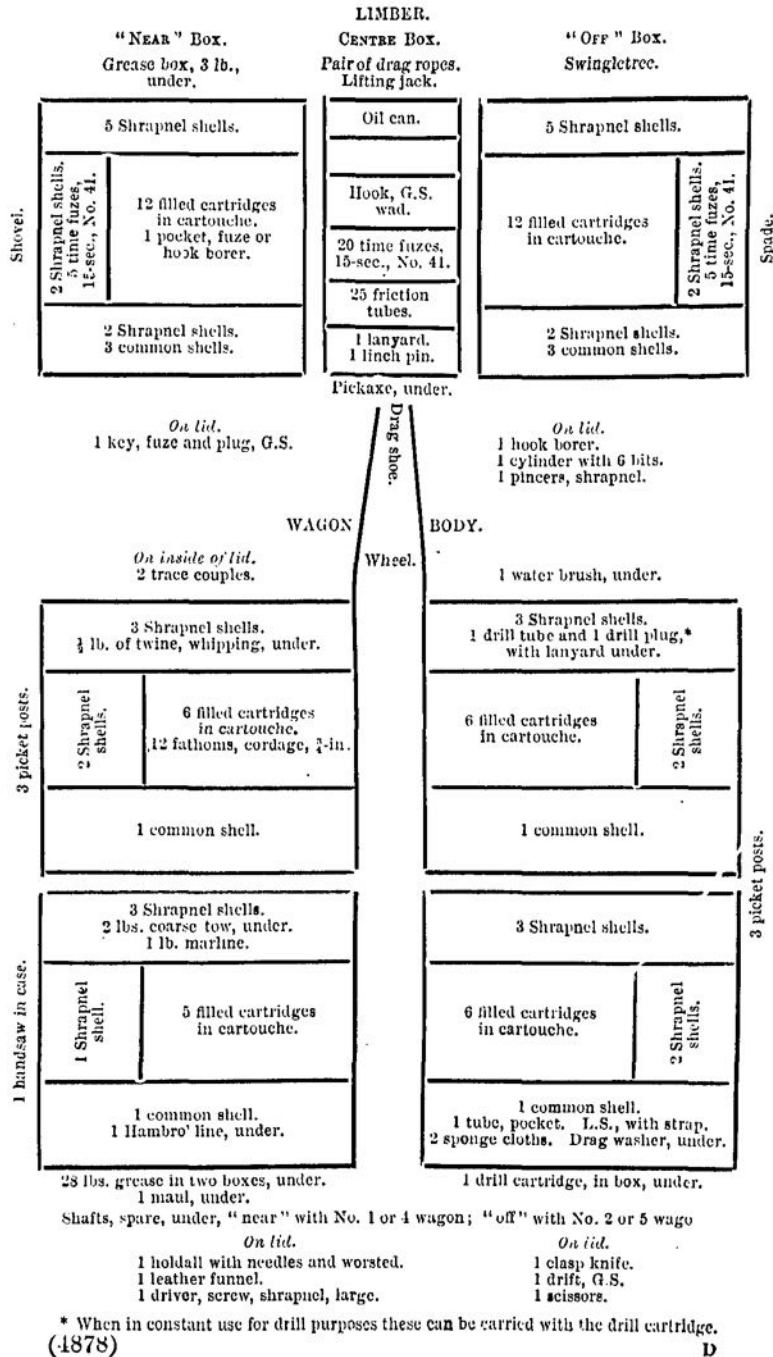

2115

D

LONDON:

Printed for Her Majesty's Stationery Office,
BY HARRISON AND SONS, ST. MARTIN'S LANE,
Printers in Ordinary to Her Majesty.

(Wt. 2397 1500 5 | 00—H & S 4878) $\frac{P. 00}{221}$

ORDNANCE, R.M.L. 16^{RB}, MARK I.

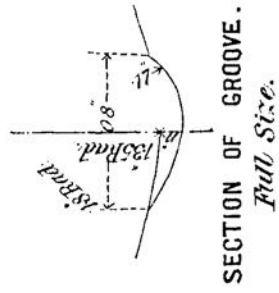
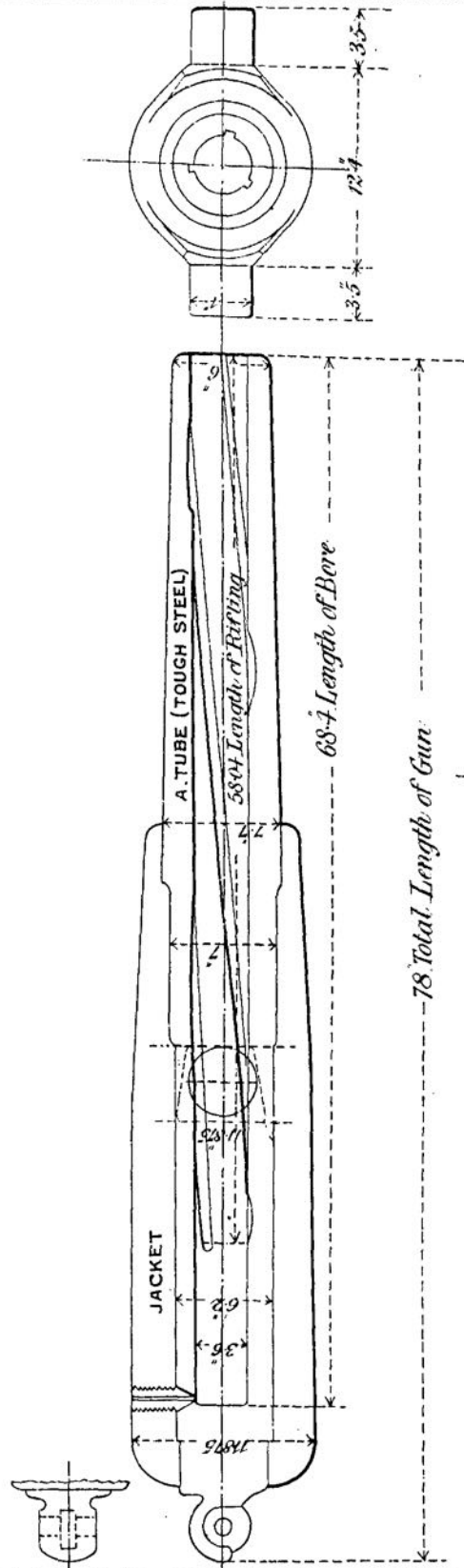

CARRIAGE, FIELD. R.M.L., 16 PR MARK II.

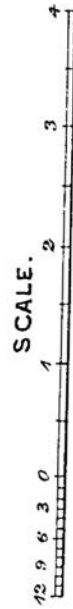
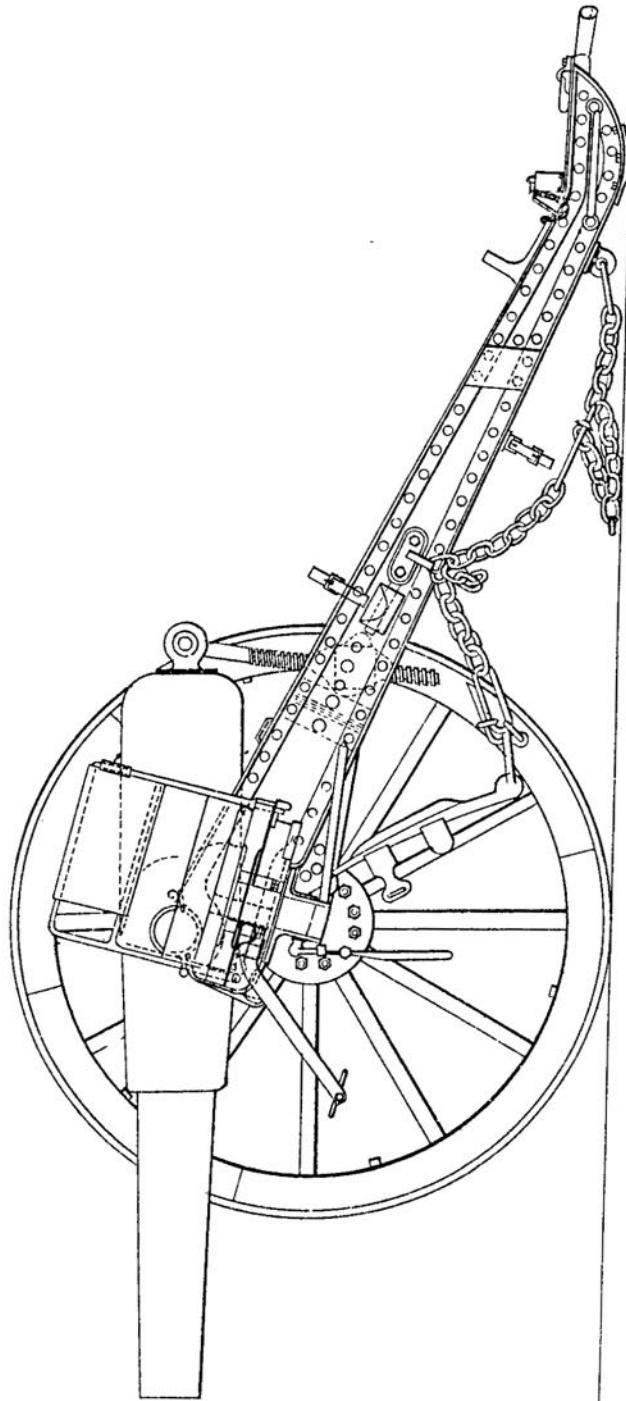

LIMBER, FIELD. R.M.L. 9 PR. MARK II

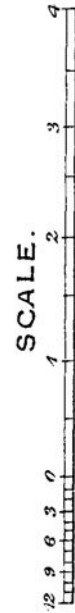
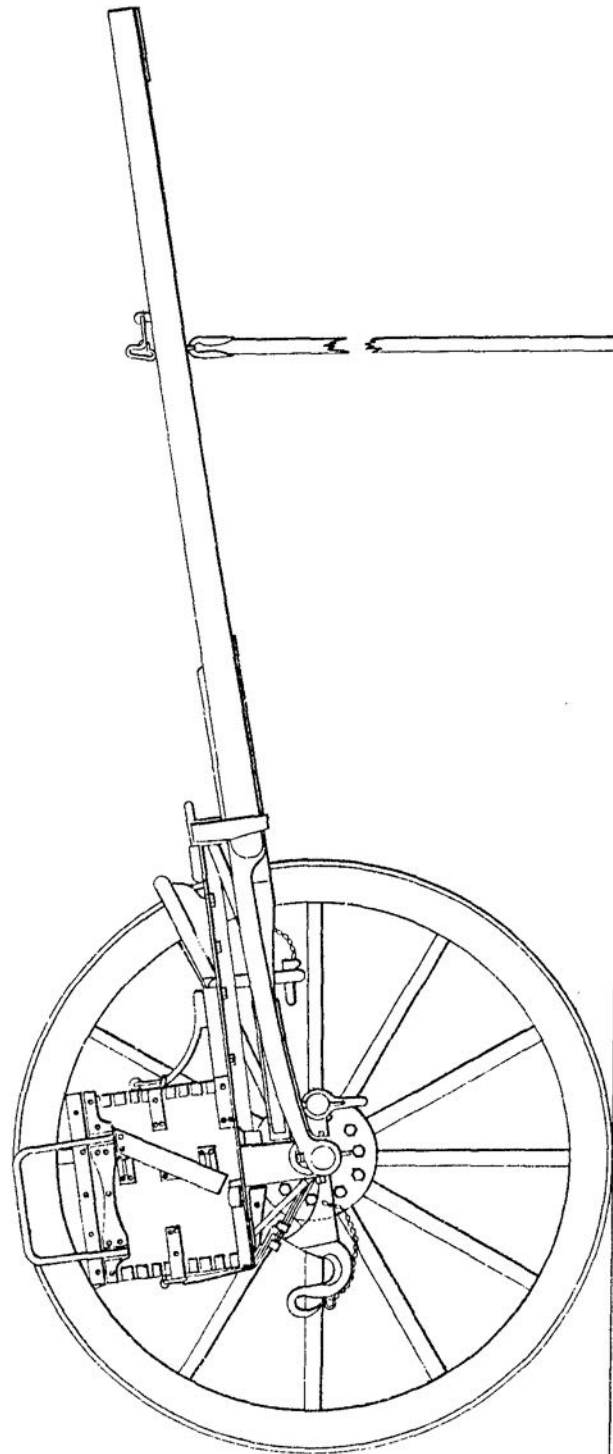

WAGON AMMUNITION, R.M.L. 16 PR, MARK II.

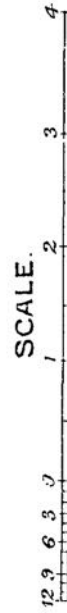
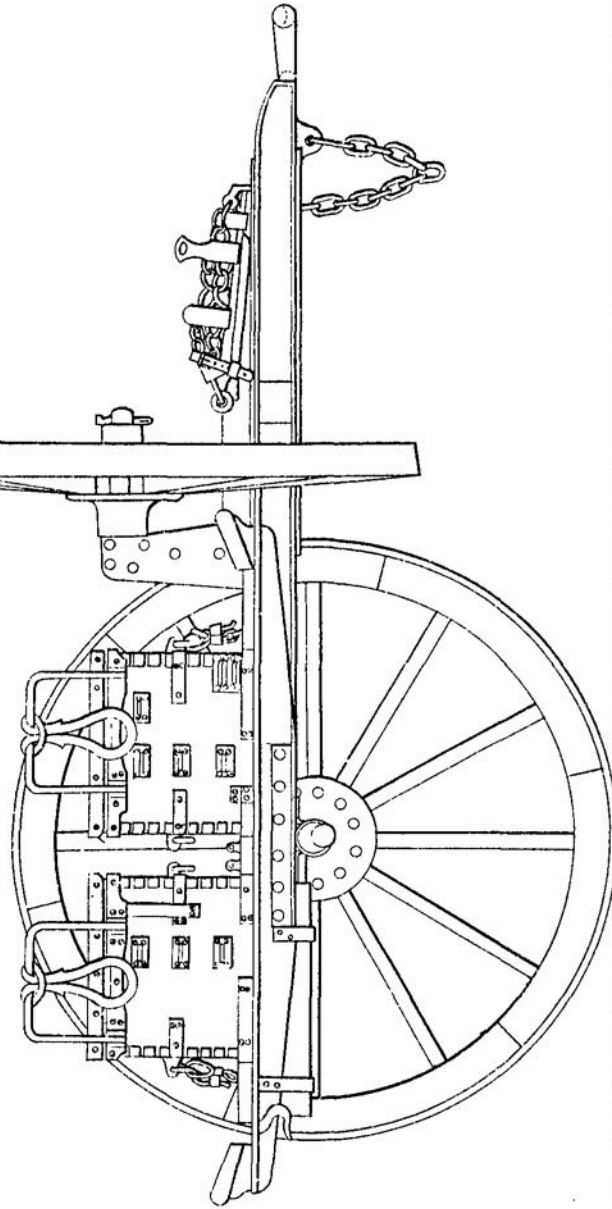

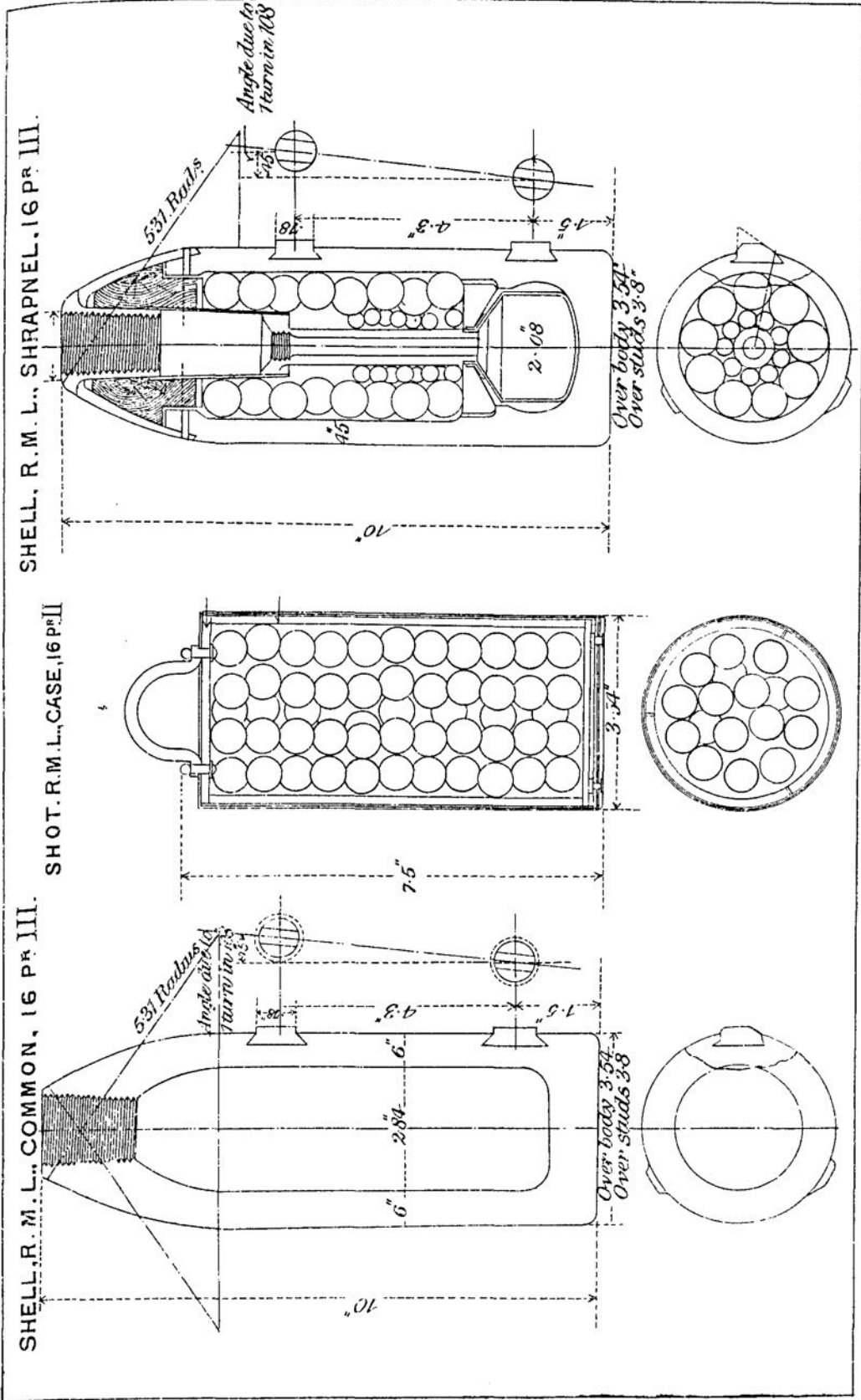

FUZE, PERCUSSION, R. L. N° 7, MARK IV.

METAL 5 IN A TIN CYLINDER.

FULL SIZE.

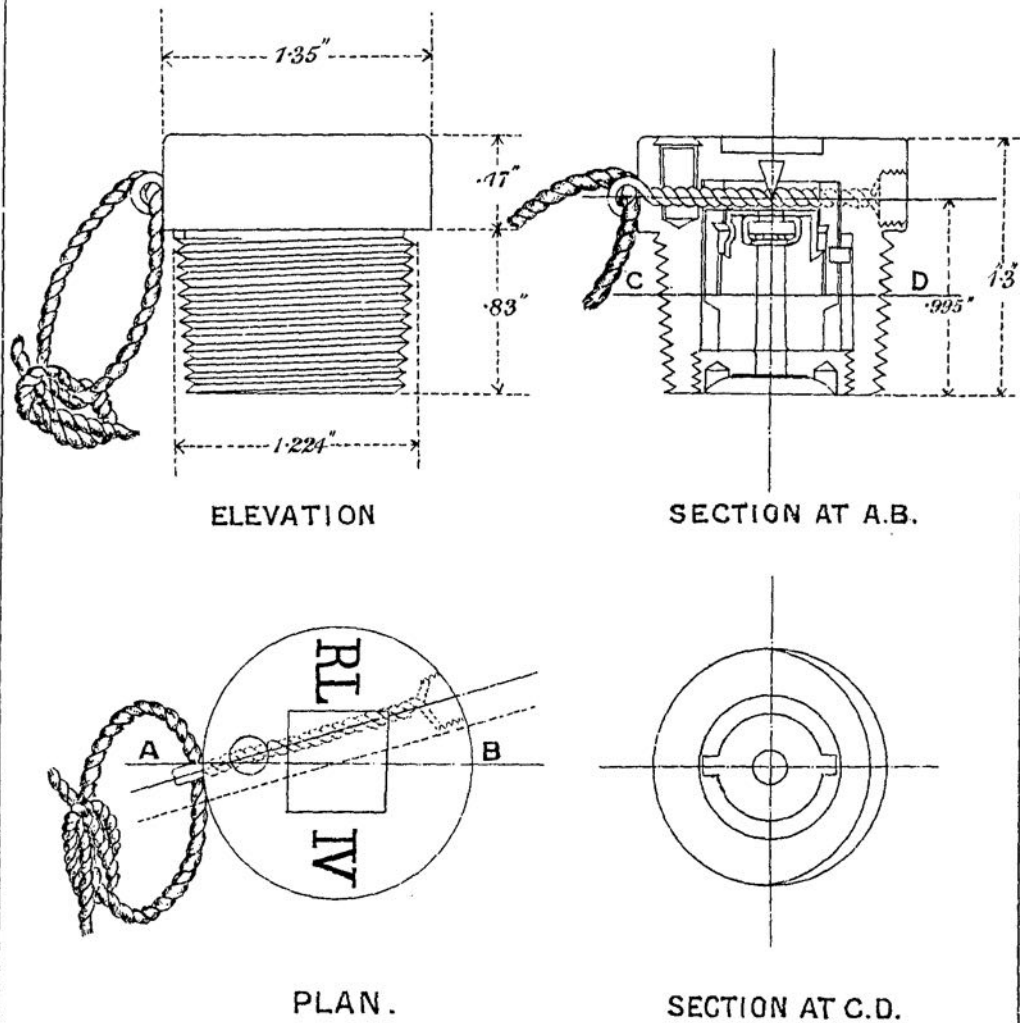

FUZE, PERCUSSION, SMALL, N°8., MARK IV.

FULL SIZE.

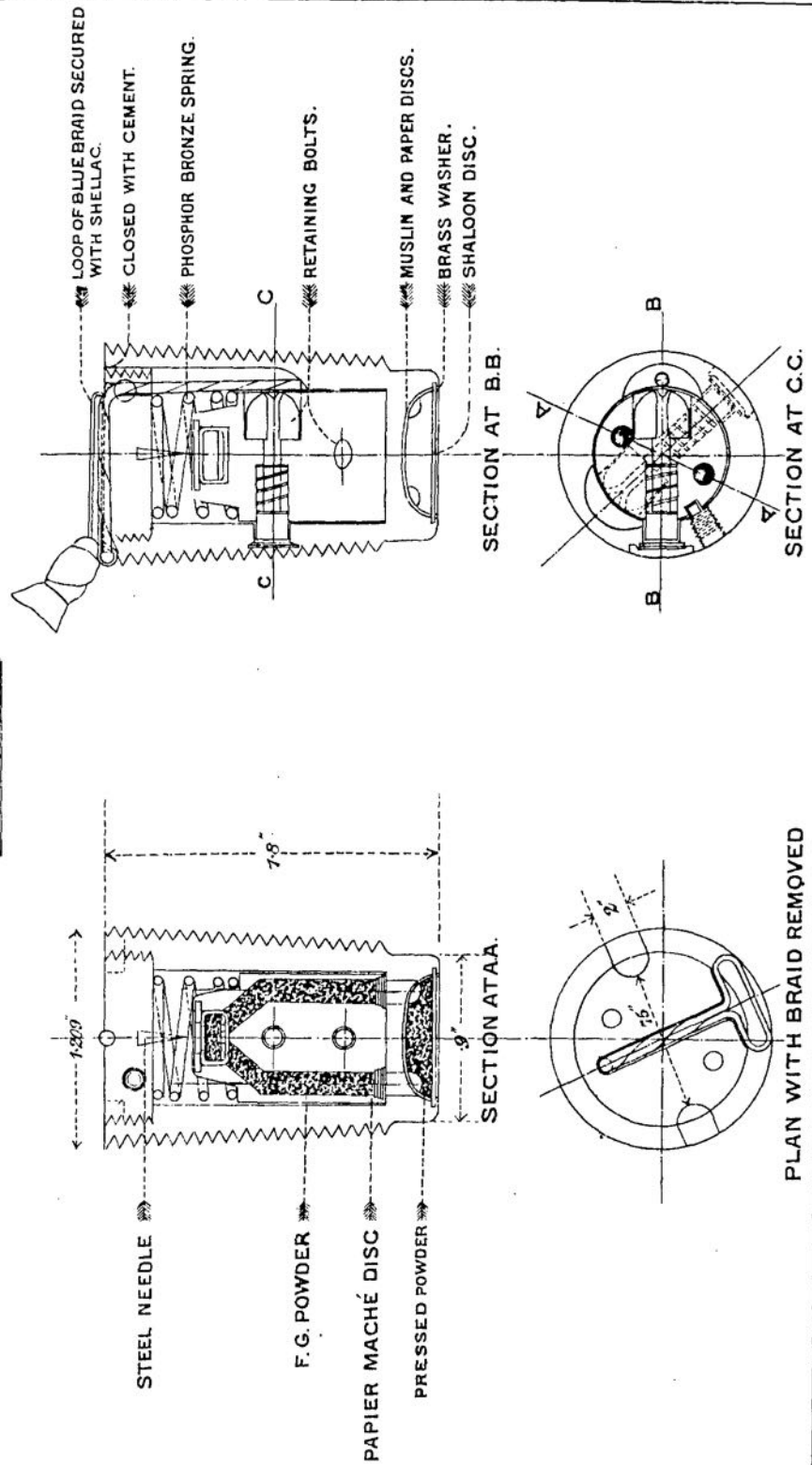

FUZE. TIME, M.L. 15 SECONDS, N°41, MARK II.

Full size.

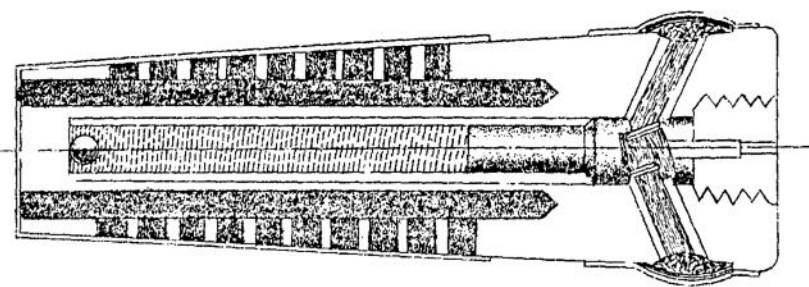

DEVELOPMENT OF PAPER SHOWING
MARKING OF FUZE.

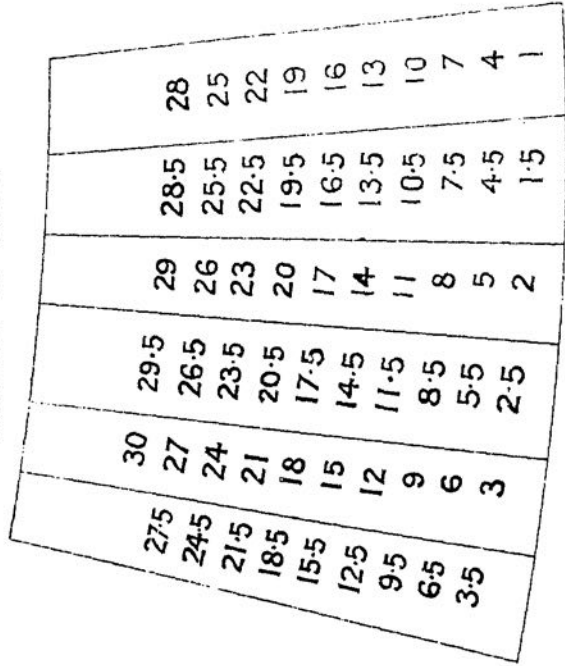

FUZE, TIME AND PERCUSSION. N° 56, MARK IV.

FULL SIZE.

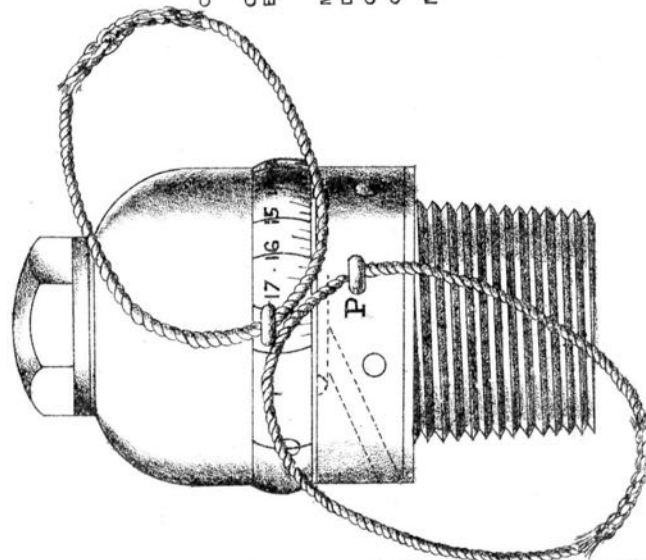

ELEVATION

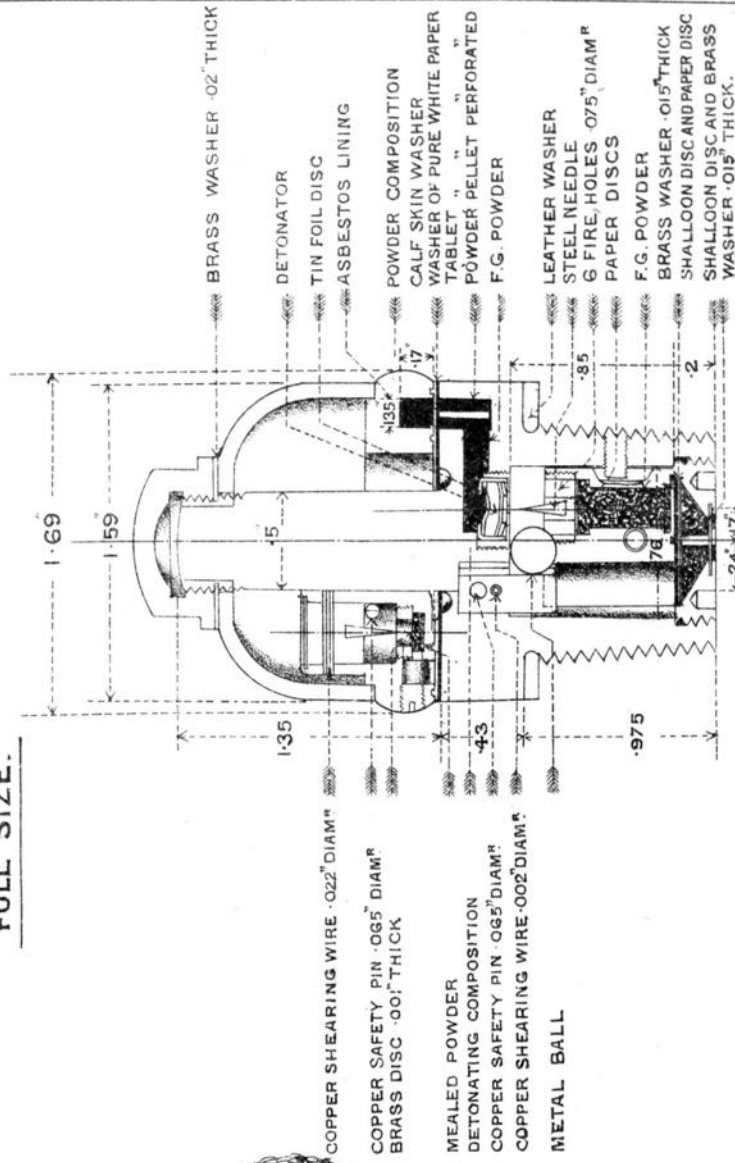

SECTION

TUBE. FRICTION. COPPER. SOLID DRAWN. WITH BALL.
(MARK II)
(Full Size.)

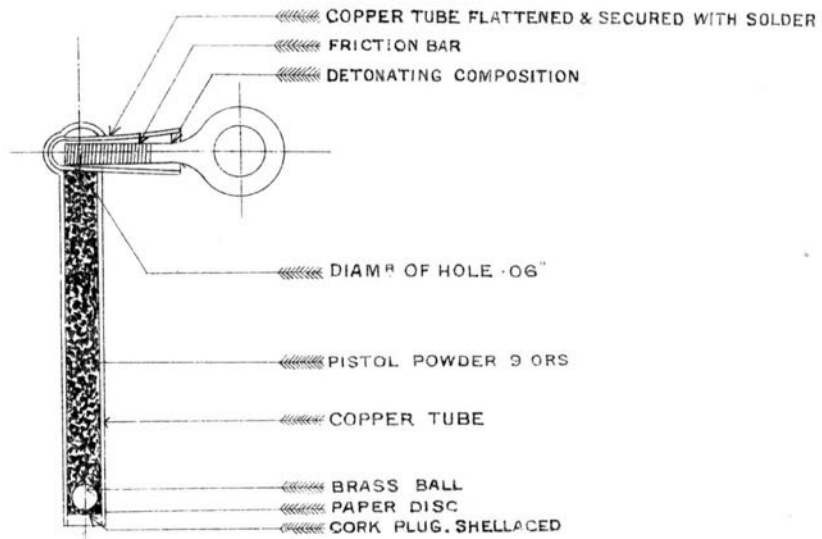

SECTION AT A.B.

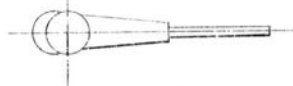

PLAN.